

GB Masonry

# Fire and Sound Technical Manual

National Collection

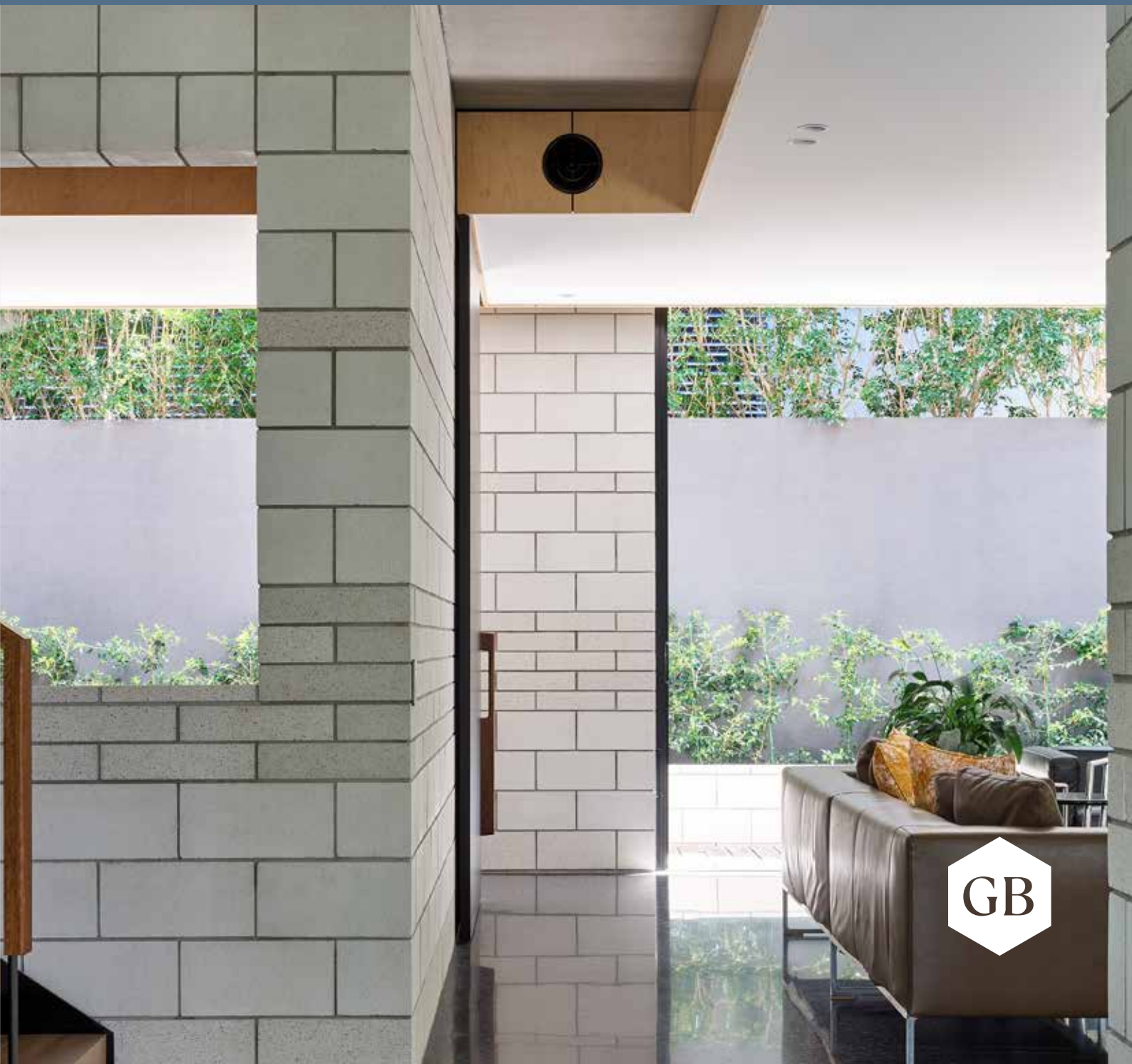

## What's inside

- 1 – Masonry for fire Resistance p<sup>03</sup>
- 2 – Research and Development p<sup>07</sup>
- 3 – Insulation FRLs p<sup>09</sup>
- 4 – Structural Adequacy p<sup>11</sup>
- 5 – Reinforced Masonry p<sup>18</sup>
- 6 – Acoustic Ratings p<sup>21</sup>
- 7 – Get in Touch p<sup>28</sup>

This document applies to the following products:

- GB Masonry coloured masonry blocks
- Architec coloured masonry blocks
- Solitary coloured masonry blocks
- Grey Blocks excluding the Alphasite, Australite & High Strength Grey Block ranges.

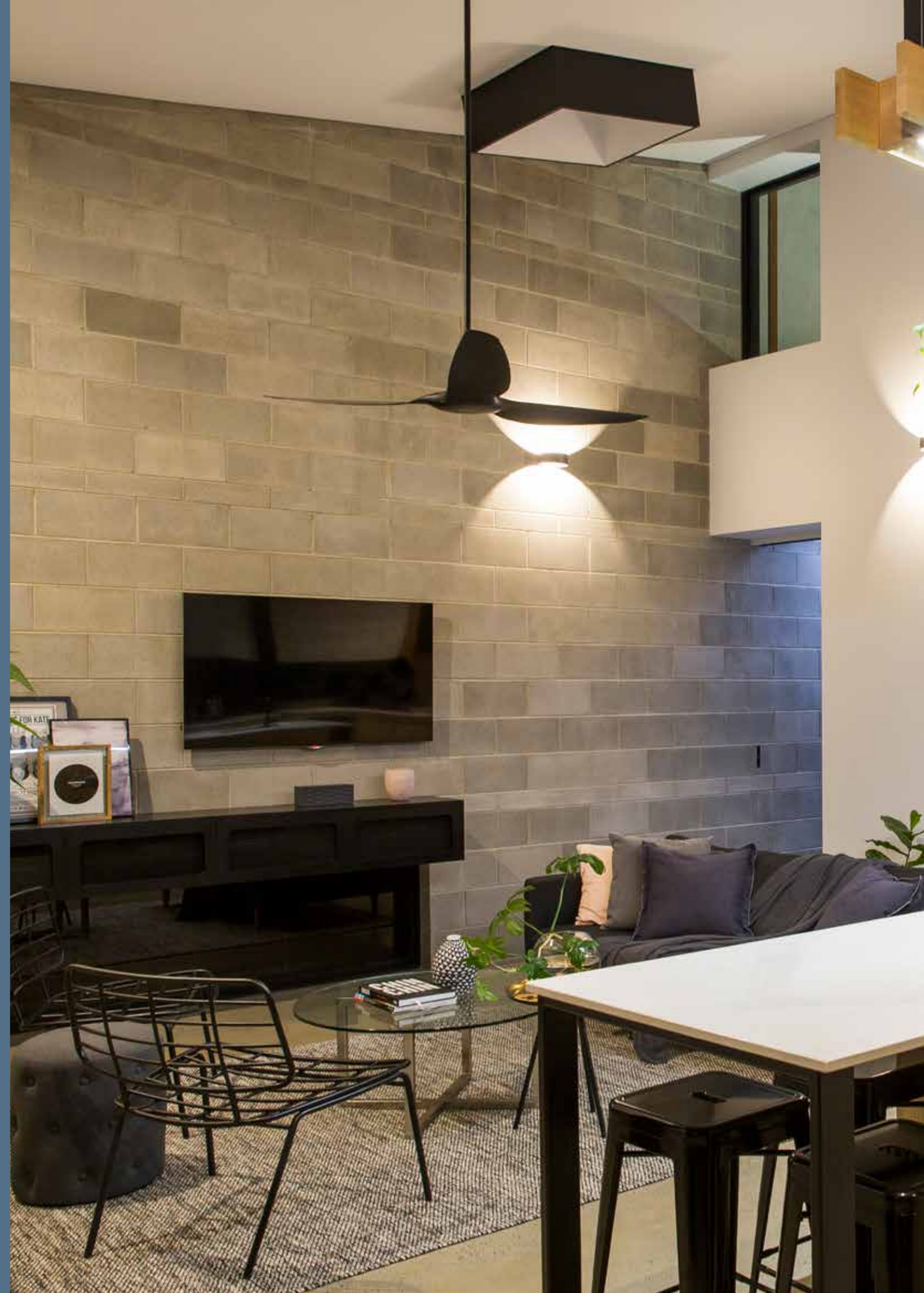

# Masonry for Fire Resistance



1

# Masonry for Fire Resistance

## Overview

When a masonry wall is subjected to fire, which is usually only on one side, a thermal gradient is created through the thickness of the wall and the expansion of the material causes bowing towards the fire source. If this bowing extends far enough it can cause collapse of the wall. If the wall does not collapse, it can crack due to internal stresses caused by restraint of the thermal expansion, or it can heat up sufficiently to allow flammable material on the side away from the fire to ignite. Both these consequences may allow the fire to spread.

The National Construction Code (NCC) requires that walls be designed in accordance with Section 1: Design for Fire Resistance of AS3700:2018, to provide the required fire resistance in buildings. This system provides an accurate method of predicting the ability of a wall to maintain its strength in a fire and to resist the spread of fire. The Austral Masonry and GB Masonry, Grey and Coloured Denseweight Concrete Masonry Block ranges comply with these standards.

Note that Denseweight products are those that contain less than 45% basalt in their mix designs.

The fire resistance level (FRL) is given in the form of three numbers, for example 180/120/120, which represent the required FRL (in minutes) for structural adequacy/integrity/insulation.

## Structural Adequacy

Structural adequacy is the ability of a wall to continue to perform its structural function for the fire resistance period. The fire resistance period for structural adequacy is a function of the slenderness ratio for the wall and is governed by three formulae in AS3700:2018, Clause 6.3.2.2. These formulae use the masonry panel's height, length, thickness and restraint conditions around the perimeter to calculate the panel's slenderness ratio for fire (Srf).

The relevant Srf's for Denseweight product ranges are outlined in AS3700:2018 Table 6.1. (<45% Basalt) The charts on pages 14 to 18 of this guide can be used to determine the FRL structural adequacy for a variety of wall sizes and restraint conditions.

Restraint at the top of a wall can be provided by a load-bearing concrete slab, head ties from infill walls to the underside of a concrete slab or ties to a braced roof frame. End restraints can be provided by bonded corners, ties to columns or buttresses with a length greater than the wall height multiplied by 0.2. Where a wall butts into and is tied to the proposed fire wall, it divides that wall into two panels for the purpose of calculating Srf.

## Integrity

Integrity is the ability of a wall to maintain its continuity and prevent the passage of flames and hot gases through cracks in the wall for the fire resistance period. Design for integrity is based on Clause 6.4.2 of AS2700 which deems that the FRL for integrity will be met if the wall meets the value for insulation and structural adequacy.

## Insulation

Insulation is governed by the material thickness of the masonry unit. For solid and cored (core volume less than 30%) masonry units, the 'material thickness' is taken as the actual thickness. The actual thickness is also used for hollow units in which all cores are filled with grout. For hollow units which are unfilled or partly filled, the 'material thickness' is the net or material volume of the unit divided by its face area, commonly referred to as 'equivalent thickness'. If the wall is cement rendered on both sides, the thickness of the thinner coating up to a maximum value of 20mm may be added to the material thickness of the wall.

## Cavity Walls

For insulation, AS3700 states the material thickness of both leaves is added together and the cavity ignored to give the "material thickness". For structural adequacy where only one leaf is load bearing, the FRL for structural adequacy is based on the loaded leaf alone and the non loaded leaf ignored. If both leaves are similarly loaded or both leaves

are non-load bearing then the thickness for structural adequacy is based on two-thirds of the sum of the thickness of the two leaves.

## Robustness

The height limits of walls when determined by design for robustness are in some cases less than those determined by design for fire resistance. These cases are indicated by secondary curves on the right hand side of the design tables.

## Chases

AS3700 Clause 6.7 states chasing of masonry subject to fire shall be kept to a minimum. The effect of chasing fire-rated walls shall be limited by structural adequacy. Vertically spanning walls may be chased vertically. Where the chase is horizontal the lengths limited to four times the wall thickness.

Vertically and horizontally spanning walls, may be chased if the length of the chase is not greater than half the height (for a vertical chase) or half the length (horizontal chase) of the wall.

Where the length of chase is greater than half the height or half the length, the wall must be designed as two walls with unsupported ends (for a vertical chase). For horizontal chases greater than half of the wall length the masonry design thickness must be reduced by the depth of the recess (horizontal chase).

## Recesses for Services

AS3700 Clause 6.6 states the effect of recesses for services on the fire resistance periods, for structural adequacy, integrity and insulation of a wall shall be ignored, provided that the depth of material removed is not greater than half the wall thickness and the total area of recesses is not more than 10,000mm<sup>2</sup> total of both faces within any 5m<sup>2</sup> of wall area. Where these limits are exceeded, the member thickness of the masonry shall be taken as the overall thickness of the wall less the depth of the recess. Where the wall is constructed of cored or hollow units, the recess can extend into the cores.

# Research & Development



# 2

## Research and Development

---

In 2011, the National Acoustic Laboratory tested Austral Masonry's 140mm thick 15-01 masonry block.

Test Report 2538-2, for a 140mm masonry block with a 64mm independent stud wall system, achieved  $R_w + C_{tr} \geq 50$  which satisfies the minimum BCA requirement for walls separating sole-occupancy units.

This wall also meets the BCA requirement to resist the transmission of impact-generated sound wherever an inter-tenancy wall separates a wet area (bathroom/laundry/kitchen etc) from a habitable room.

This test and other previous tests provided data for Day Design Pty Ltd Acoustic Engineers to provide opinions on the performance of other masonry wall systems.

The 15-01 masonry units achieve the NCC fire rating requirements for low to high-rise home unit walls before adding any lining system.

# Maximum Insulation FRLs

# 3

# Maximum Insulation FRLs in Minutes

# Structural Adequacy

				Maximum Slenderness Ratio (Srf)					
				Hollow & Solid	18	17	16	15.5	15
				Reinforced & Core-filled	36	36	36	36	36
Code	Dimensions L x H x T (mm)	Unit Type	f <sub>uc</sub> MPa	FRL Insulation (minutes)					
				60	90	120	180	240	
10-01 DW	390 × 190 × 91	Cored	15						
10-31 DW	390 × 190 × 90	Solid	15						
8001LB DW	230 × 162 × 110	Cored	10						
12-01 DW	390 × 190 × 110	Hollow	15						
12-801 DW	390 × 190 × 110	Cored	15						
15-01 DW	390 × 190 × 140	Hollow	15						
15-42 DW	390 × 190 × 140	Reinforced & core filled	15						
15-48 DW	390 × 190 × 140	Reinforced & core filled	15						
15-801 DW	390 × 190 × 140	Cored	15						
20-01 DW	390 × 190 × 190	Hollow	15						
20-42 DW	390 × 190 × 190	Reinforced & core filled	15						
20-48 DW	390 × 190 × 190	Reinforced & core filled	15						
30-42 DW	390 × 190 × 190	Reinforced & core filled	15						
30-48 DW	390 × 190 × 290	Reinforced & core filled	15						

This data represents average results from commercial production lots and is for general description purposes only. Figures are accurate at date of publication and subject to change without notice. Contact Austral Masonry for confirmation of product specification.



# Structural Adequacy

## How to Use the Charts

First, find the page with the required FRL: 60, 90, 120, 180 or 240 minutes. Next, find the graph with the restraint conditions of your proposed wall. Finally, plot the intersection of your wall's height and length on the appropriate graph.

The thickness required is represented by those lines clear of the intersection point. Denseweight and GB Masonry that is designed for other loads (vertical, bending, earthquake, etc.) can be checked for its FRL structural adequacy by using the following graphs.

The three formulae are graphed, with a line for each wall thickness: 90, 110, 140 and 190mm.

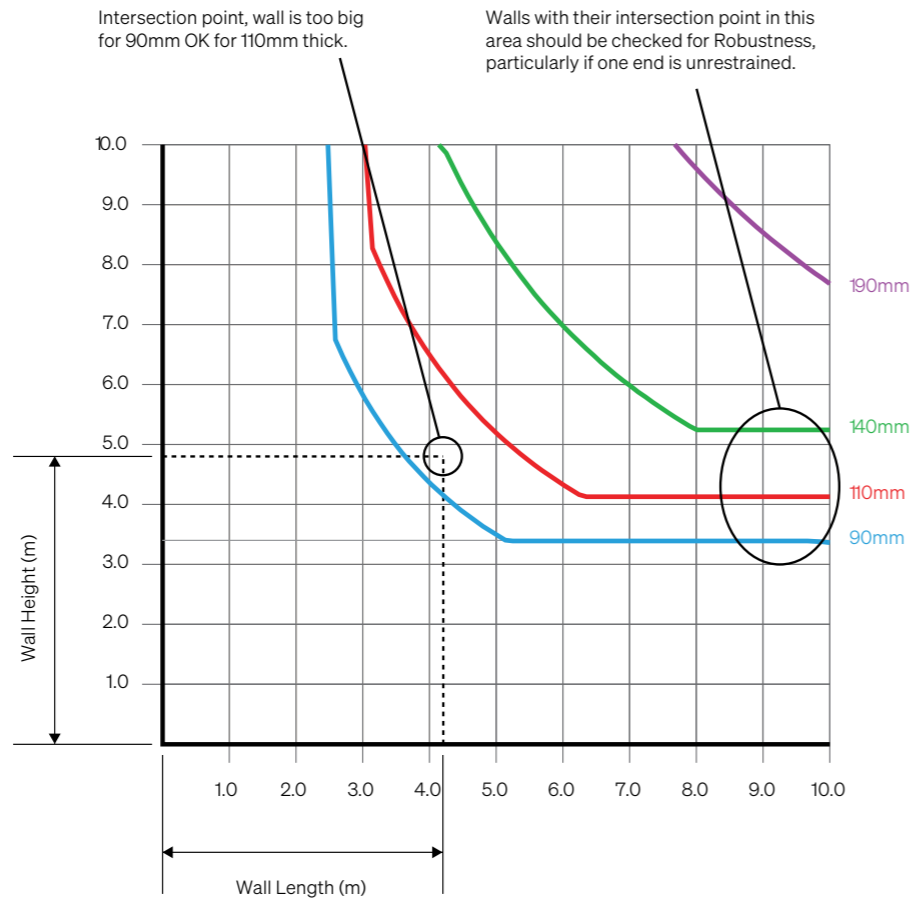

# Structural Adequacy 60 Minute FRL (Srf >18)

**Laterally supported along top, both ends and base.**

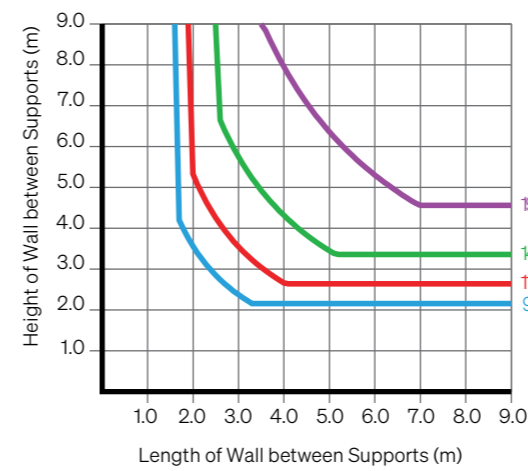

**Laterally supported along top, one end and base.**

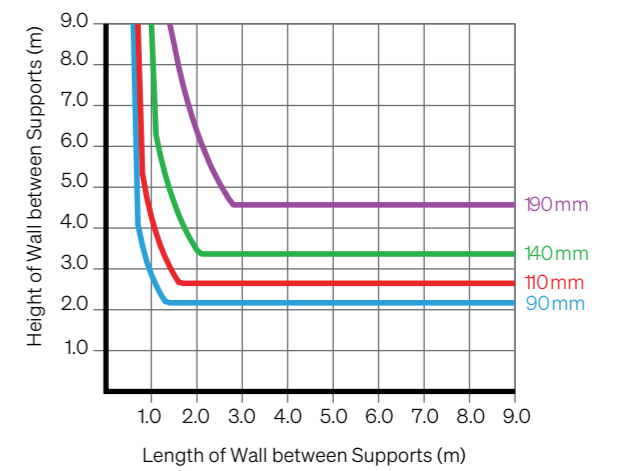

**Laterally supported along both ends and base.**

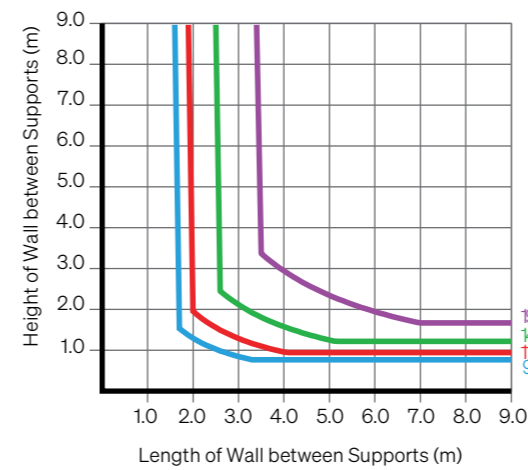

**Laterally supported along one end and base.**

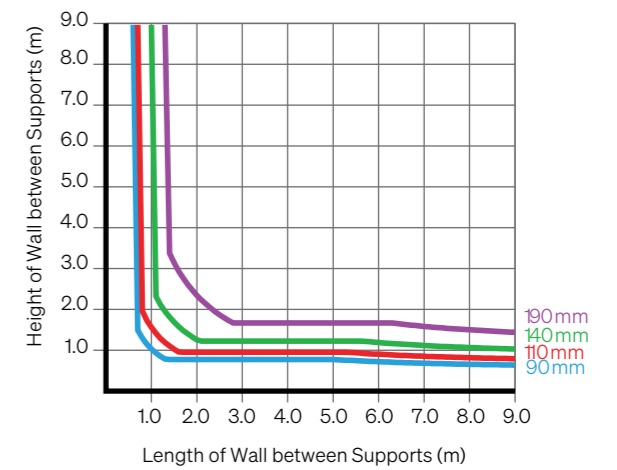



# Structural Adequacy

## 90 Minute FRL (Srf >17)

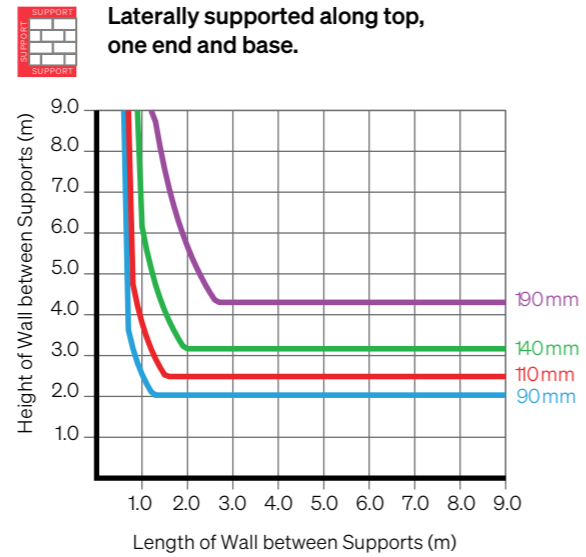
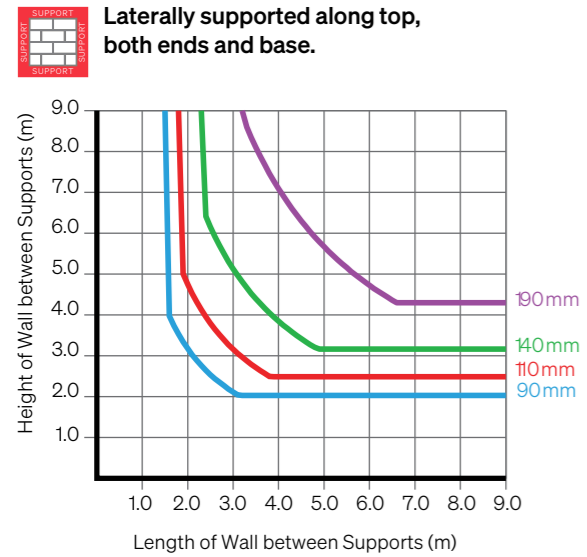

# Structural Adequacy

## 120 Minute FRL (Srf >16)

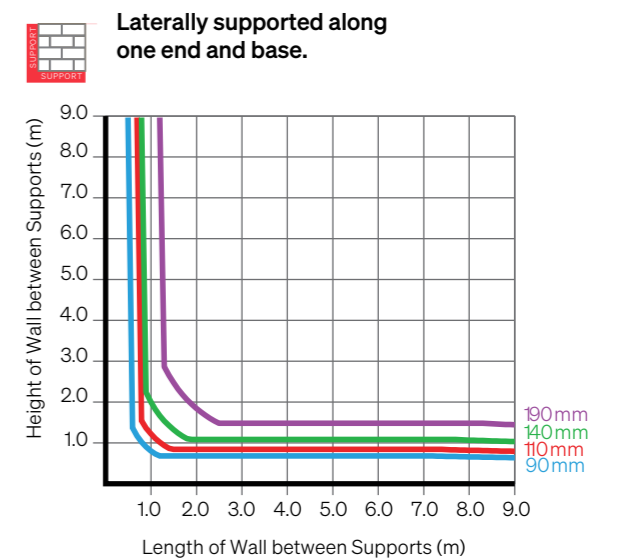
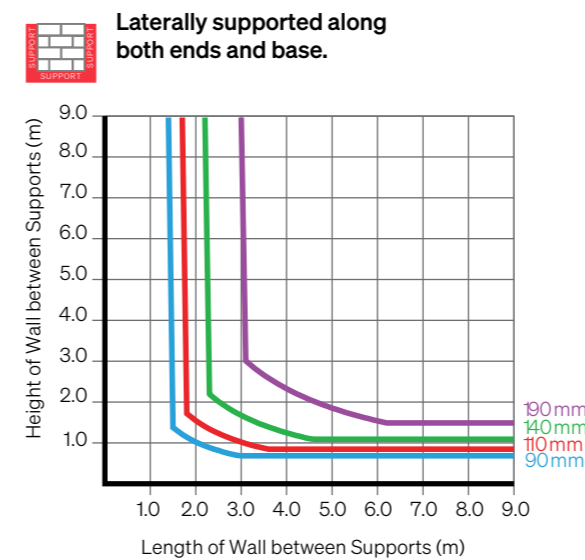
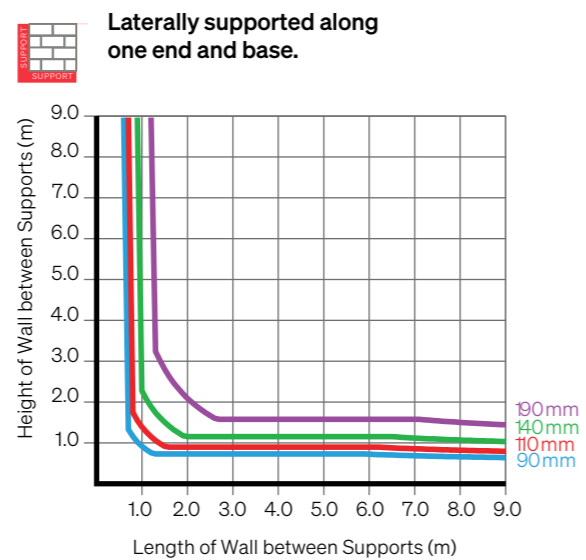
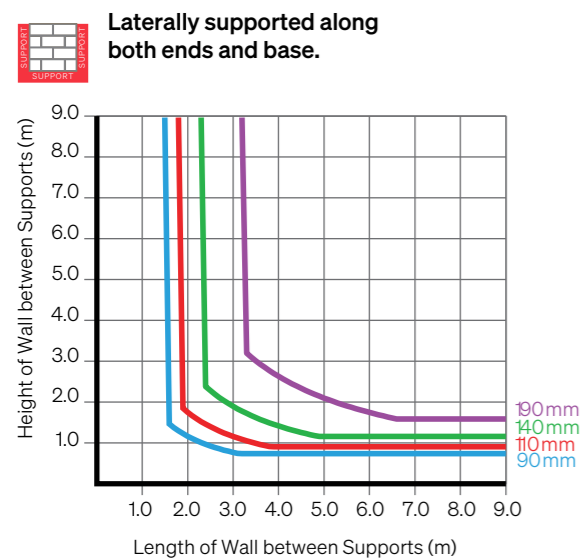
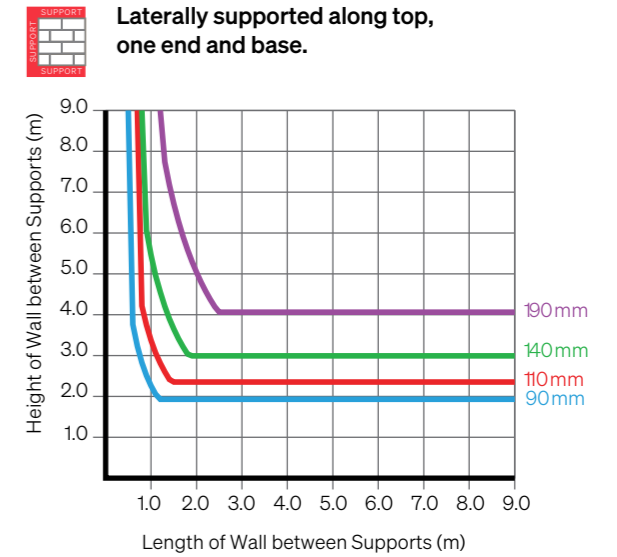
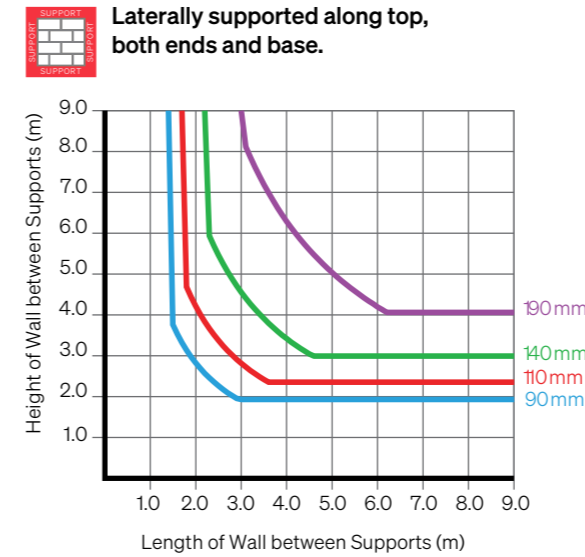

# Structural Adequacy

## 180 Minute FRL (Srf >15.5)

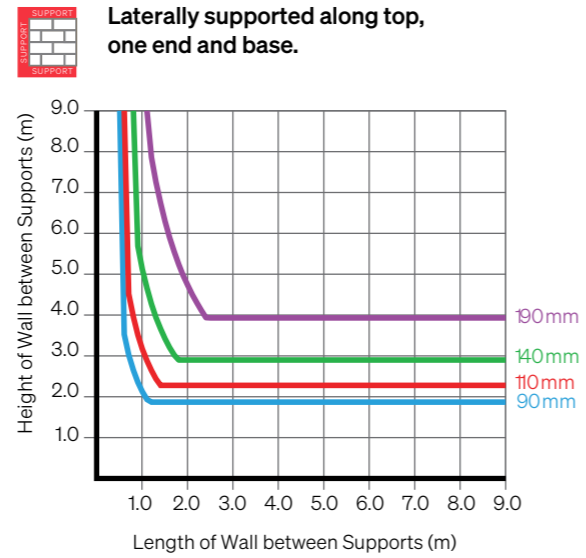
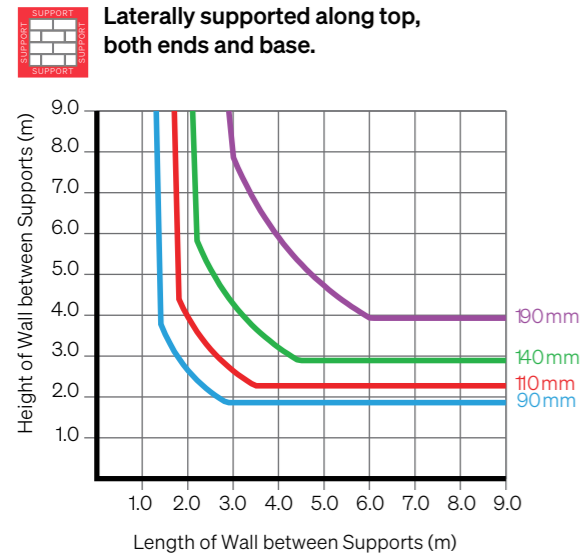

# Structural Adequacy

## 240 Minute FRL (Srf >15)

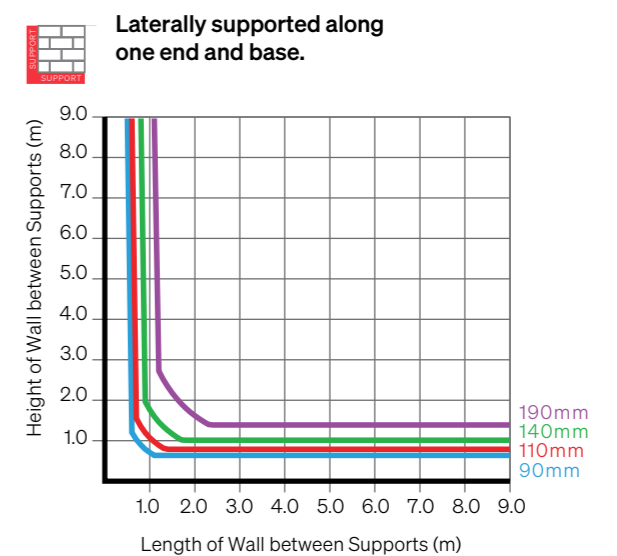
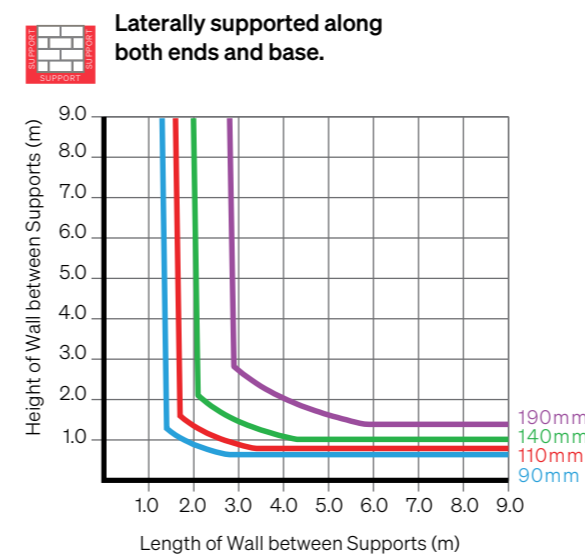
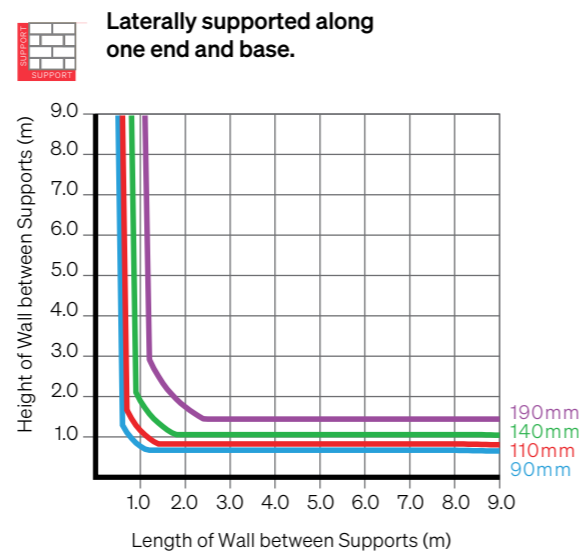
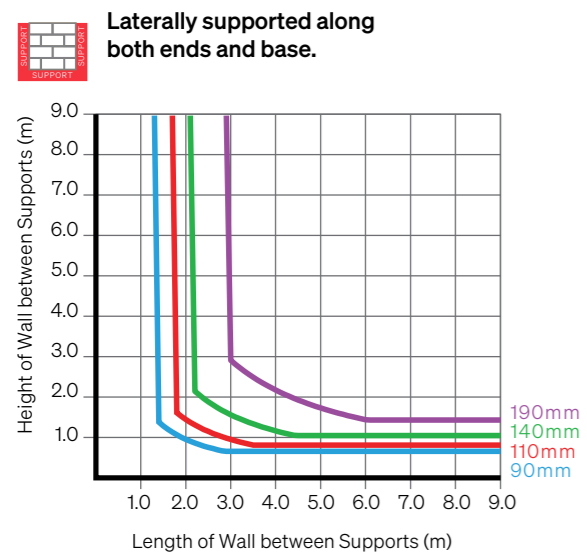
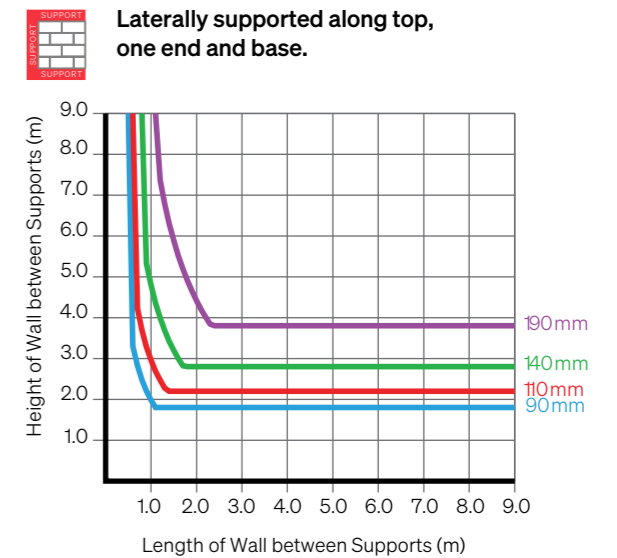
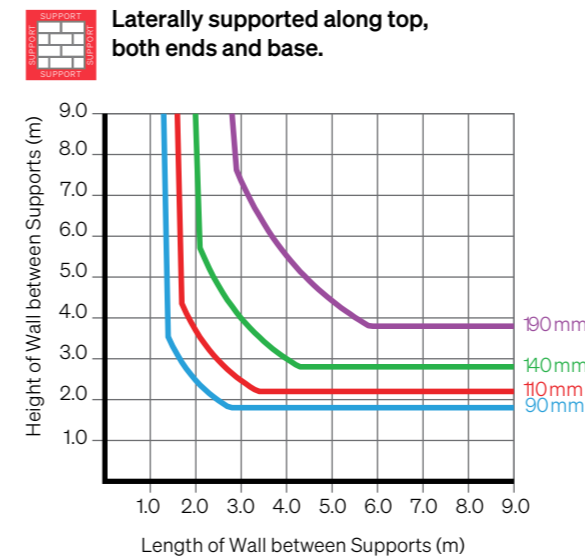

# Reinforced Masonry

## Reinforced Masonry 60 to 240 minutes

Maximum vertical load on wall + 11.25H kN/m where H is in metres. Reinforced masonry is to comply with AS3700:2018, Section 8.

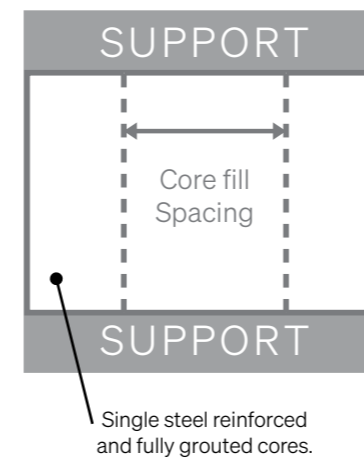

Maximum Wall Height (Metres)	Steel	Core Fill Spacing (Metres)	Leaf Thickness (mm)
4.000	N12	Every 10th core (2m)	140 mm
5.040	N16	Every 10th core (2m)	140 mm
4.800	N12	Every 10th core (2m)	190 mm
6.400	N16	Every 10th core (2m)	190 mm
6.840	N16	Every 8th core (1.6m)	190 mm

# 5

# Reinforced Masonry

## 60 to 240 minutes

Maximum vertical load on wall + 11.25H kN/m where H is in metres. Reinforced masonry is to comply with AS3700:2018, Section 8.

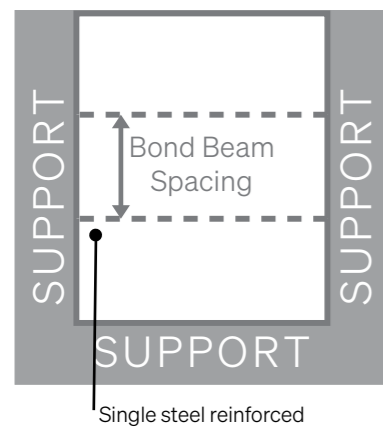

Maximum Wall Height (Metres)	Steel	Core Fill Spacing (Metres)	Leaf Thickness (mm)
4.000	N12	Every 10th core (2m)	140 mm
5.040	N16	Every 10th core (2m)	140 mm
4.800	N12	Every 10th core (2m)	190 mm
6.400	N16	Every 10th core (2m)	190 mm
6.840	N16	Every 8th core (1.6m)	190 mm

# Acoustic Ratings

# 6

# Acoustic Ratings

## Overview

This manual provides guidance on the measurement of acoustic ratings, the BCA requirements for residential buildings and details of testing and development of successful wall systems for Denseweight and GB Masonry.

The BCA requires that building elements have certain levels of insulation from airborne noise and impact sound. Rw is the weighted sound reduction index, which is used to measure the acoustic performance of a construction system.

It is a single number quantity for the airborne sound insulation rating of building elements. As the acoustic performance of a material or construction improves, the higher the Rw value will be.

The Rw rating system has two correction factors (C and Ctr) which take into account different spectra of noise sources. C relates mainly to high frequency noise while Ctr relates to lower frequency noises. These correction factors are used to indicate the performance drop of the wall in the corresponding frequency range.

Rw + Ctr is the value of the index when the low frequency correction factor (Ctr) is applied. For example, if a wall is measured as Rw (C;Ctr) of 55 (-1;-4) the Rw rating is 55 and Rw + Ctr is  $55 + (-4) = 51$ .

This brochure is designed to provide you with up to date data and information on the acoustic performances of Austral's masonry wall systems.

## Building Code of Australia Acoustic Requirements

The NCC requires that walls separating sole-occupancy units in Class 1, 2 and 3 buildings are required to have an

Rw + Ctr of not less than 50. In addition, the construction must be discontinuous if the wall separates a habitable room (living room, dining room, bedroom, study and the like) from a wet room (kitchen, bathroom, sanitary compartment or laundry). Walls in Class 2 or 3 buildings that separate a sole-occupancy unit from a plant room, lift shaft, stairway, public corridor, public lobby or the like must have an Rw of not less than 50. If this wall separates a sole-occupancy unit from a plant room or a lift shaft, the construction must be discontinuous.

Discontinuous construction requires a minimum 20mm cavity between two separate leaves. If wall ties are to be used they must be resilient wall ties.

**Construction: Habitable to habitable and wet to wet.**  
Requirements:  $Rw + Ctr \geq 50$ .

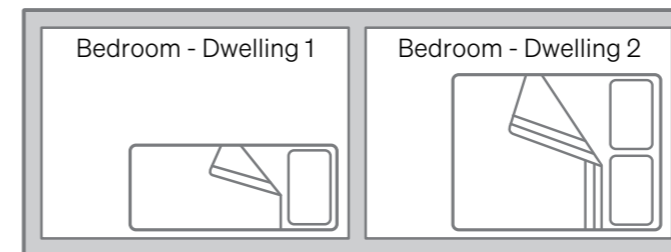

**Construction: Habitable to wet.**  
Requirements:  $Rw + Ctr \geq 50$  with discontinuous construction.

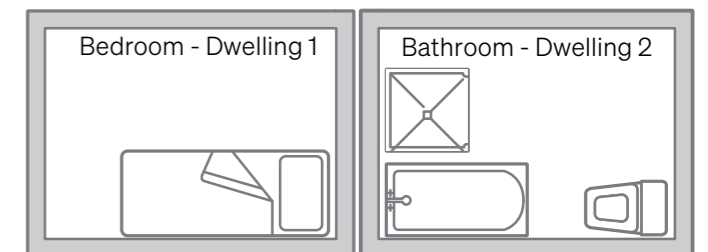

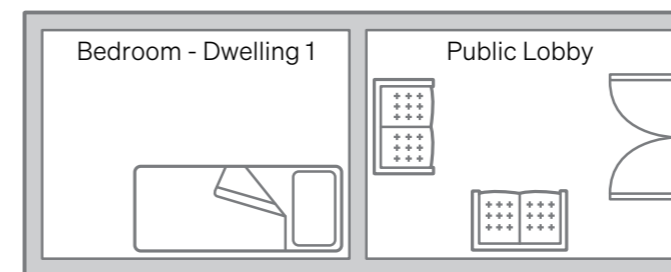

**Construction: Sole occupancy to corridor or public area.**  
Requirements:  $Rw + > 50$  with discontinuous construction (if lift shaft or plant room).



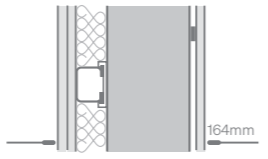

# Acoustic Ratings Performance of Masonry Walls

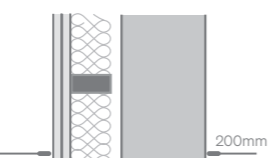
## 90mm Masonry Systems Code: Densweight 10.01 & 10.31

<p><b>Corridor Wall: <math>R_w \geq 50</math></b> Including unit to stairs, unit to foyer Bare Wall: <math>R_w</math> 40</p>	<p>2 layers of 13mm standard-core plasterboard on 28mm furring channel on standard clips Minimum cavity: 30mm with 25 mm Glasswool or 30mm Polyester in cavity.</p>		<p>13mm standard-core plasterboard, daub-fixed</p>
<p><b>Party Wall: <math>R_w + C_{tr} \geq 50</math></b> NB: Wall ties must be resilient, to comply with discontinuous construction.</p>	<p>13 mm Sound Rated plasterboard on 70mm timber stud, 20mm clear of masonry with R1.5 Glasswool or Polyester in cavity.</p>		<p>10mm cement render</p>
<p><b>Party Wall: <math>R_w + C_{tr} \geq 50</math></b> NB: Wall ties must be resilient, to comply with discontinuous construction.</p>	<p>2 layers of 10mm standard-core plasterboard on 70mm timber stud, 20mm clear of masonry with R1.5 Glasswool or Polyester in cavity.</p>		<p>Bare Wall</p>

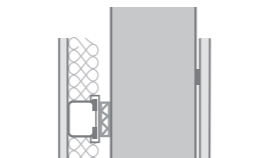

## 110mm Masonry Systems Code: Densweight 12.01 (60 min FRL & 12-709 (90 min FRL)

<p><b>Corridor Wall: <math>R_w \geq 50</math></b> Including unit to stairs, unit to foyer Bare Wall: <math>R_w</math> 42 (12-01)</p>	<p>13mm standard-core plasterboard on 28mm furring channel on resilient clips. Minimum cavity: 30mm with 25 mm Glasswool or 30mm Polyester in cavity.</p>		<p>13mm standard-core plasterboard, daub-fixed</p>
<p><b>Party Wall: <math>R_w + C_{tr} \geq 50</math></b> NB: Not suitable for wet-to-dry areas. See Discontinuous detail below.</p>	<p>2 layers of 13mm standard-core plasterboard on 28mm furring channel on resilient clips. Minimum cavity: 50mm with 50mm Glasswool or 50mm Polyester in cavity.</p>		<p>13mm standard-core plasterboard, daub-fixed</p>
<p><b>Party Wall: <math>R_w + C_{tr} \geq 50</math></b> Discontinuous Construction. Suitable for all Party Walls. If wall ties are required, they must be resilient type.</p>	<p>13mm sound rated plasterboard on 64mm steel studs 20mm clear of masonry with 75 mm Glasswool or 65mm Polyester in cavity.</p>		<p>2 layers of 10mm standard-core plasterboard</p>

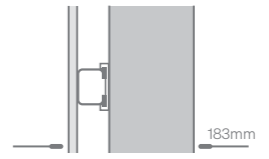
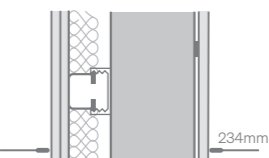
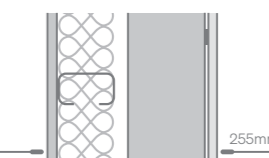
## 140mm Masonry Systems Code: Densweight 15.01 (60min FRL) & 15.709 (120min FRL)

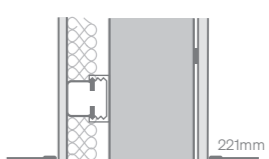
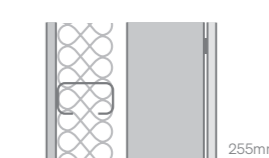

<p><b>Corridor Wall: <math>R_w \geq 50</math></b> Including unit to stairs, unit to foyer Bare Wall: <math>R_w</math> 43 (15-01)</p>	<p>13mm standard-core plasterboard on 28mm furring channel on standard clips Minimum cavity: 30mm.</p>		<p>Bare Wall</p>
<p><b>Party Wall: <math>R_w + C_{tr} \geq 50</math></b> NB: Not suitable for wet-to-dry areas. See Discontinuous detail below.</p>	<p>2 layers of 13 mm standard-core plasterboard on 28mm furring channel on standard clips Minimum cavity: 50mm with 50mm Glasswool or 50mm Polyester in cavity.</p>		<p>13mm standard-core plasterboard, daub-fixed</p>
<p><b>Party Wall: <math>R_w + C_{tr} \geq 50</math></b> Discontinuous Construction. Suitable for all Party Walls. If wall ties are required, they must be resilient type.</p>	<p>13 mm standard-core plasterboard on 64mm steel studs 20mm clear of masonry with 75mm Glasswool or 65mm Polyester in cavity.</p>		<p>13mm standard-core plasterboard, daub-fixed</p>

## 140mm Grouted Systems Code: Densweight 15.48 FRL

<p><b>Corridor Wall: <math>R_w \geq 50</math></b> Including unit to stairs, unit to foyer Bare Wall: <math>R_w</math> 50</p>	<p>No lining required</p>		<p>No lining required</p>
<p><b>Party Wall: <math>R_w + C_{tr} \geq 50</math></b> (both options) NB: Not suitable for wet-to-dry areas. See Discontinuous detail below.</p>	<p>2 layers of 13 mm standard-core plasterboard on 28mm furring channel on standard clips. Minimum cavity: 30mm with 25mm Glasswool or 30mm Polyester in cavity.</p>		<p>13mm standard-core plasterboard, daub-fixed</p>
	<p>13 mm standard-core plasterboard on 28mm furring channel on standard clips. Minimum cavity: 50mm with 50mm Glasswool or 50mm Polyester in cavity.</p>		<p>13mm standard-core plasterboard, daub-fixed</p>
<p><b>Party Wall: <math>R_w + C_{tr} \geq 50</math></b> Discontinuous Construction. Suitable for all Party Walls. If wall ties are required, they must be resilient type. (No ties are better)</p>	<p>13mm sound rated plasterboard on 64mm steel studs 20mm clear of masonry with 75 mm Glasswool or 65mm Polyester in cavity.</p>		<p>13mm standard-core plasterboard, daub-fixed</p>

# Acoustic Ratings Performance of Masonry Walls

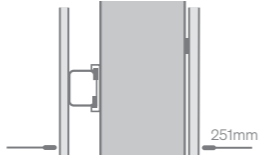
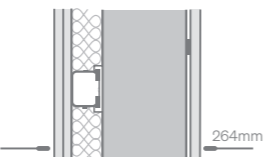
## 190mm Masonry Systems Code: Densweight 20.01

<p><b>Corridor Wall: <math>R_w \geq 50</math></b> Bare Wall: <math>R_w</math> 45 Including unit to stairs, unit to foyer</p>	<p>13 mm standard-core plasterboard on 28mm furring channel on standard clips. Minimum cavity: 30mm</p>		<p>13mm standard-core plasterboard, daub-fixed</p>
<p><b>Party Wall: <math>R_w + C_{tr} \geq 50</math></b> NB: Not suitable for wet-to-dry areas. See Discontinuous detail below.</p>	<p>2 layers of 13 mm standard-core plasterboard on 28mm furring channel on standard clips. Minimum cavity: 30mm with 25mm Glasswool or 30mm Polyester in cavity.</p>		<p>13mm standard-core plasterboard, daub-fixed</p>
<p><b>Party Wall: <math>R_w + C_{tr} \geq 50</math></b> Discontinuous Construction. Suitable for all Party Walls. If wall ties are required, they must be resilient type.</p>	<p>13 mm standard-core plasterboard on 64mm steel studs 20mm clear of masonry with 75mm Glasswool or 65mm Polyester in cavity.</p>		<p>13mm standard-core plasterboard, daub-fixed</p>

## 190mm Grouted Systems Code: Densweight 20.48

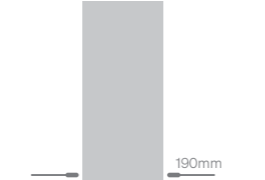
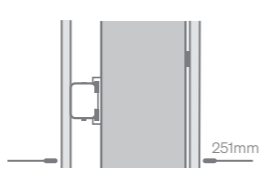
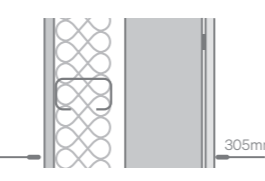
<p><b>Corridor Wall: <math>R_w \geq 50</math></b> Bare Wall: <math>R_w</math> 50 Including unit to stairs, unit to foyer.</p>			<p>No lining required</p>
<p><b>Party Wall: <math>R_w + C_{tr} \geq 50</math></b> NB: Not suitable for wet-to-dry areas. See Discontinuous detail below.</p>	<p>13 mm standard-core plasterboard on 28mm furring channel on standard clips. Minimum cavity: 30mm with 25mm Glasswool or 30mm Polyester in cavity.</p>		<p>13mm standard-core plasterboard, daub-fixed</p>
<p><b>Party Wall: <math>R_w + C_{tr} \geq 50</math></b> Discontinuous Construction. Suitable for all Party Walls. If wall ties are required, they must be resilient type. (No ties are better)</p>	<p>13 mm standard-core plasterboard on 64mm steel studs 20mm clear of masonry with 75mm Glasswool or 65mm Polyester in cavity.</p>		<p>13mm standard-core plasterboard, daub-fixed</p>

## Backed by Brickworks

Local expertise. Global quality. Brickworks Building Products is one of Australia's biggest building material manufacturers. With heritage going all the way back to one of Australia's founding brick producers, we're proud of our reputation for design, innovation and sustainability.

# BRICKWORKS

## AUSTRALIA

 australbricks

 australmasonry

 australprecast

 southern cross  
cement

 bristilerroofing

 BOWRAL BRICKS

DANIEL ROBERTSON

NUBRIK

GB Masonry

URBANSTONE

Terraçade

 CAPITAL BATTENS

## NORTH AMERICA

 Glen-Gery

Sioux City Brick  
Since 1913

Lawrenceville  
BRICK

Cushwa  
BRICK





Visit. [gbmasonry.com.au](http://gbmasonry.com.au)  
Call. 1300 Masonry

A BRAND OF

**BRICKWORKS**

