

# TERRAÇADE TN<sub>5</sub>

*technical manual – sixth edition*

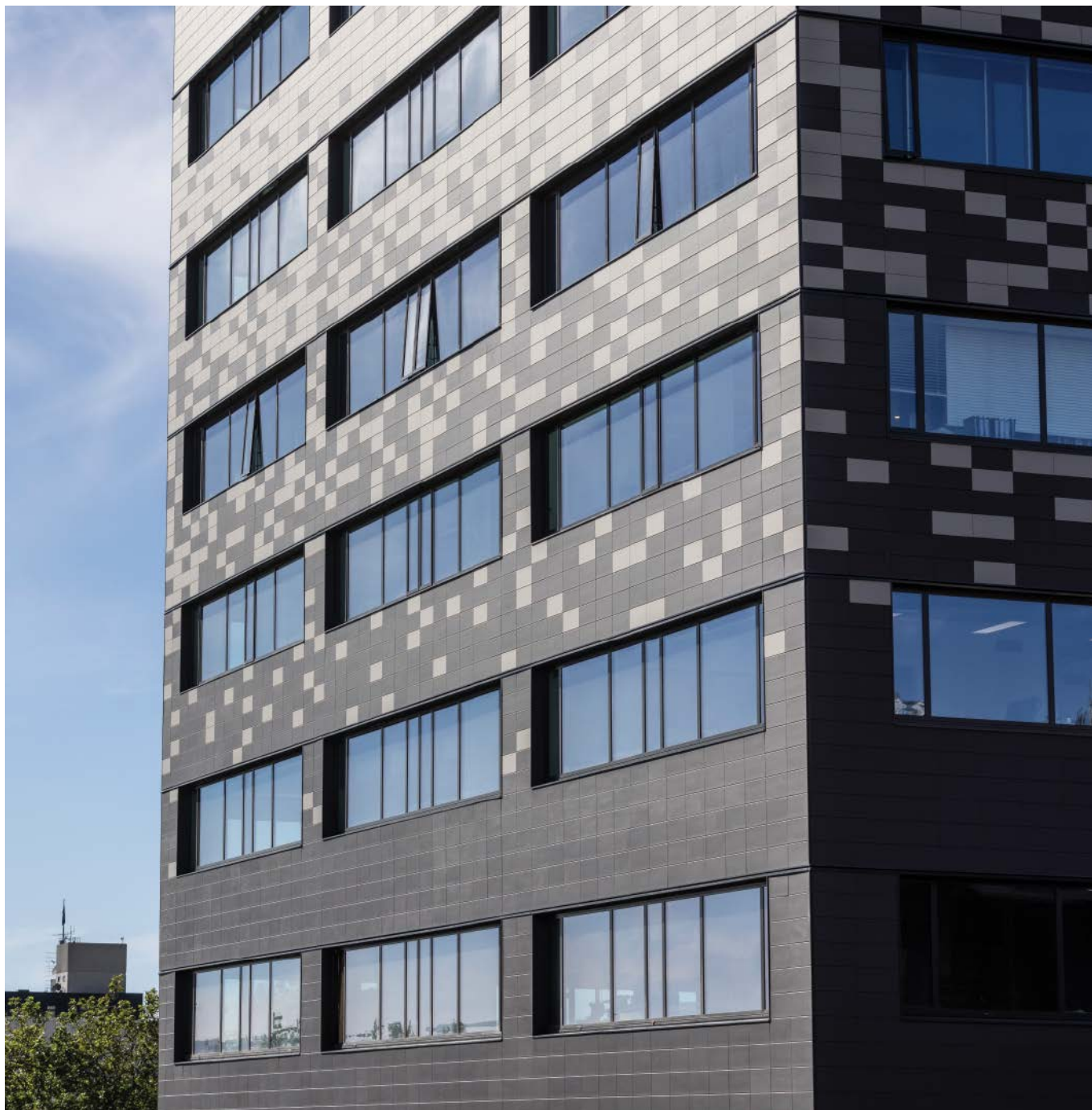

**terraçade™**



# CONTENTS

<b>Section</b>	<b>Page</b>
<b>01. Safe Working Instructions</b>	<b>05</b>
Site Preparation	06
<b>02. System Description</b>	<b>07</b>
<b>03. Structural Performance</b>	<b>16</b>
<b>04. Technical Specifications</b>	<b>28</b>
Materials Schedule and Properties	29
Fasteners	31
System Performance	32
<b>05. Components</b>	<b>33</b>
<b>06. System Design – Common Details</b>	<b>40</b>
Overview	42
Side Detail	43
Horizontal Detail	44
External Corner	45
Internal Corner	46
Base Detail	47
Parapet Detail	48
Window Sill	49
Window Head	50
Window Jamb	51
Set-Out Tool	52
Rake Detail	53
Top Restraint for Earthquake Zones	54
Timber – Horizontal Detail	55
Timber – Vertical Detail	56
Timber – Termite Detail (Recessed Slab)	57
Steel – Horizontal Detail	58
Steel – Vertical Detail	59
Concrete – Horizontal Detail	60
Concrete – Vertical Detail	61
Masonry – Horizontal Detail	62
Masonry – Vertical Detail	63
<b>07. Installation</b>	<b>65</b>
<b>08. Disassembly Process</b>	<b>70</b>
<b>09. Maintenance Guide</b>	<b>71</b>

*For the most up to date information on  
Terraçade products and the latest version  
of this manual, please refer to our website.  
[www.terraçade.com.au](http://www.terraçade.com.au)*



# SAFE WORKING INSTRUCTIONS



For the most up to date information on Terraçade products and the latest version of this manual, please refer to our website; [www.terraçade.com.au](http://www.terraçade.com.au)

# SAFE WORKING INSTRUCTIONS

## Site Preparation

### Reworking Tiles

Silica dust can be liberated from the Terraçade TN tiles when they are reworked. Chronic inhalation of crystalline silica has been associated with impairment of lung function. Please refer to SDS for Terraçade, which is available from the Terraçade website ([www.terraçade.com.au](http://www.terraçade.com.au)) for further information. Care should be taken when reworking Terraçade TN tiles to maintain the exposure to crystalline silica below the Exposure Standard proscribed by Worksafe Australia (0.1 mg/m<sup>3</sup>). Safe working procedures should include:

- Utilising a wet saw when cutting or reworking tiles. Contact the saw manufacturer for further details.
- Wear appropriate personal protective equipment, such as approved dust mask and safety goggles, when utilising power tools or abrasive hand tools on the tiles.
- Ensure that dust is disposed of during clean up and disposal appropriately, by either wetting or vacuuming. (refer to the below diagram).

### Using Brick/Tile Saws or Power Saws

- Ensure that adequate personal protective equipment, such as approved safety glasses, gloves, dust mask and hearing protection, is worn.
- Use a wet saw to cut tiles, or ensure that adequate ventilation or dust extraction equipment is available if dry cutting is used.

### Handling

- Care should be taken when handling suspension rails and trims to avoid cuts and abrasions. The use of appropriate gloves may be of benefit. Extra care should be taken when handling cut pieces of tiles.
- It is recommended that large packs of suspension rails should be broken up, so that they may be handled individually.
- Ensure clear passage when moving the suspension rails and trims due to their size. Also allow for adequate storage of the suspension rails and trims to avoid trip hazards.
- Take care when handling cut tiles, to avoid cuts or abrasions from sharp surfaces or broken tiles.
- Consider manual handling issues when lifting tiles.
- Ensure that an adequate number of people are available to support the weight of the roll when rolling out the membrane.

### Surrounding Materials

- All materials should be stored to avoid damage. Particularly, ensure that the hangers on the suspension rails are protected from distortion and the edges and corners of the tiles are protected from chipping.
- Protect the tiles, rails and trims from exposure to rain, water or chemicals during storage.
- Ensure that pressure water jet cleaning of any surrounding surfaces is conducted prior to the installation of the tiles.
- Protect aluminium components during chemical cleaning of nearby materials, especially acid cleaning.

### Recommended Safety Protection



Face Masks P1 or P2 type approved to the relevant New Zealand Standards.



Safety Goggles approved to the relevant New Zealand Standards.



Hearing Protection approved to the relevant New Zealand Standards.



Clean up, wet down or vacuum



Dispose containment of dust.

# SYSTEM DESCRIPTION



For the most up to date information on Terraçade products and the latest version of this manual, please refer to our website; [www.terraçade.com.au](http://www.terraçade.com.au)

# SYSTEM DESCRIPTION

## Overview

TERRAÇADE IS AN INNOVATIVE AUSTRALIAN TERRACOTTA FAÇADE SYSTEM DEVELOPED TO PROVIDE THE NATURAL BEAUTY AND AESTHETIC APPEAL OF TERRACOTTA TO YOUR PROJECT.

Terraçade TN has been designed in consultation with Australia's leading engineers to act as a rain screen and rear ventilated façade system. It is a lightweight system and is simple to install.

### System Assembly

The Terraçade TN system is easily installed as the tiles are attached securely by a purpose designed vertical suspension rail. The system can be installed onto a timber framed, steel framed, concrete or masonry structural wall.

The Terraçade TN system is comprised of:

- A galvanised vertical suspension rail incorporating unique tile hangers,
- Lightweight clay tiles designed to fit securely onto the suspension rails,
- Joint Channel or Joint Angle,
- Fitment sponge,
- Anti-lifting block.

In addition, a full range of trims are available in anodised or powder coated finish to complement or highlight your design, including:

- Internal and external corners,
- A surround that accommodates windows, doors, bases and parapets.

### Benefits of Terraçade TN

Terraçade TN is a rear ventilated façade, which creates an airspace outside the load-bearing wall. This minimises thermal transfer to the building structure, improving comfort levels and providing energy savings. The airspace provides natural ventilation with a chimney effect, which facilitates the removal of heat, humidity and condensation away from the building structure.

### Exposure Grade

Terraçade TN tiles are classified as exposure grade so they can be used in all environments including severe marine environments and areas subject to heavy industrial pollution.

The coastal version incorporates ZAM® precoated steel or stainless steel suspension rails to ensure that the Terraçade TN will stand the test of time

### Tested Performance

The terracotta tile acts as part of a rain screen system, where the tile is the first line of defence against water penetration and must be used in conjunction with a waterproofed and drained backup wall. The system has previously demonstrated structural and weather performance when used with a waterproof membrane, as shown through the extensive wind load and water penetration testing conducted to AS/NZS 4284.

The performance of the Terraçade TN tiles has been extensively tested in Austral's NATA accredited laboratory to AS/NZS 4456 and AS/NZS 10545 and in independent NATA accredited laboratories. In addition to the standard TN system a coastal version of Terraçade TN is available for severe marine environments.

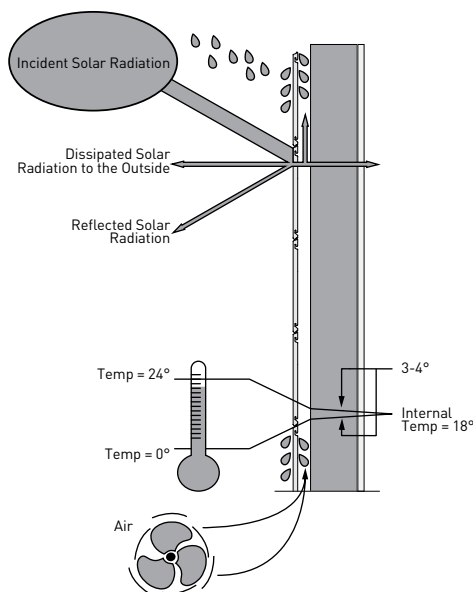



# SYSTEM DESCRIPTION

## *Terraçade TN System with Butt Joint*

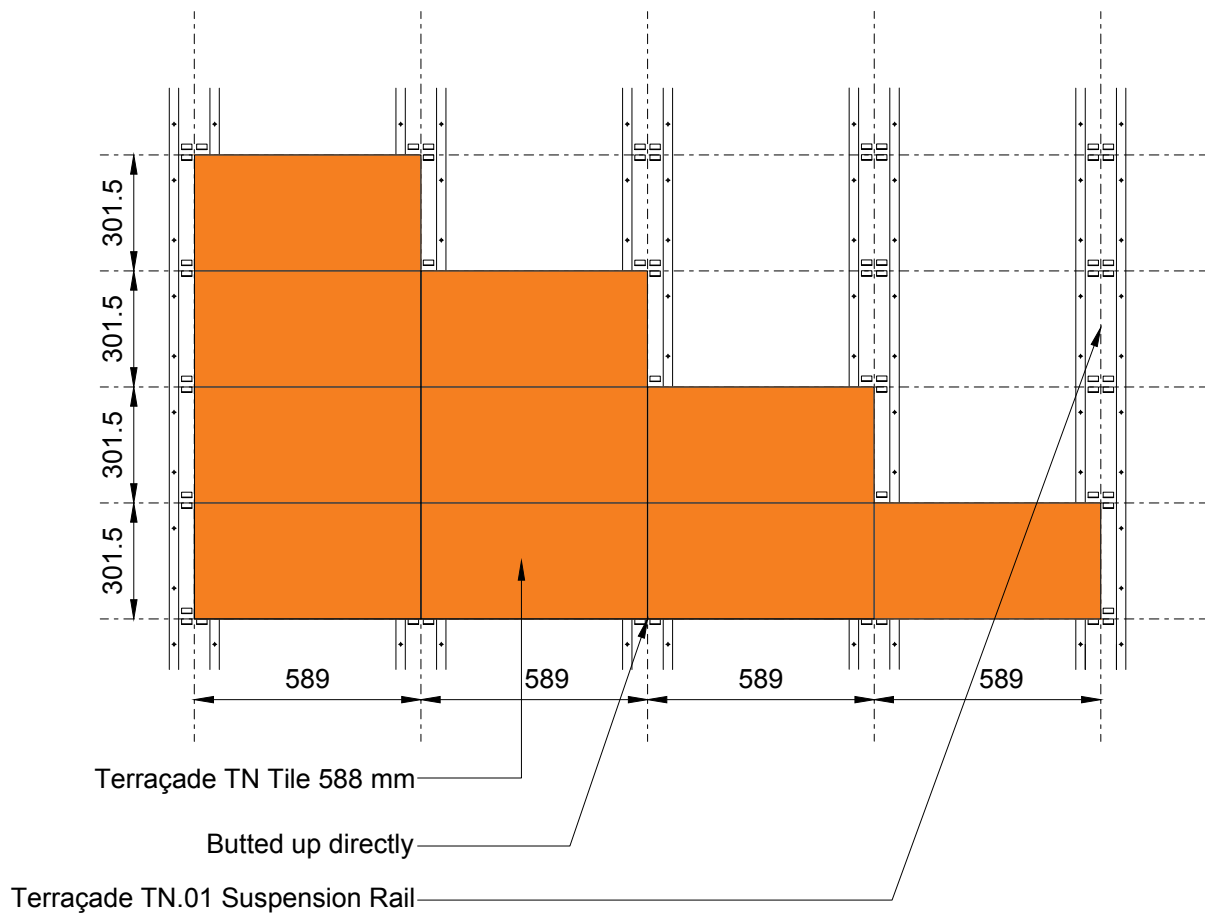

### ISSUE F-0122

© Copyright 2022. Australian New Zealand Patent & Design Registrations. This drawing is indicative only and allowances should be made for material and onsite variations. The component and the assembly details demonstrate a design methodology only. Assembly and documentation drawings should only be undertaken after reference and compliance with the

relevant component's technical data. The diagram is not to scale. For more tailored solutions to suit individual applications, please contact Brickworks Building Products. Brickworks Building Products reserves the rights to add, alter or delete components without prior notice.

# SYSTEM DESCRIPTION

## *Terraçada TN System with Butt Joint*

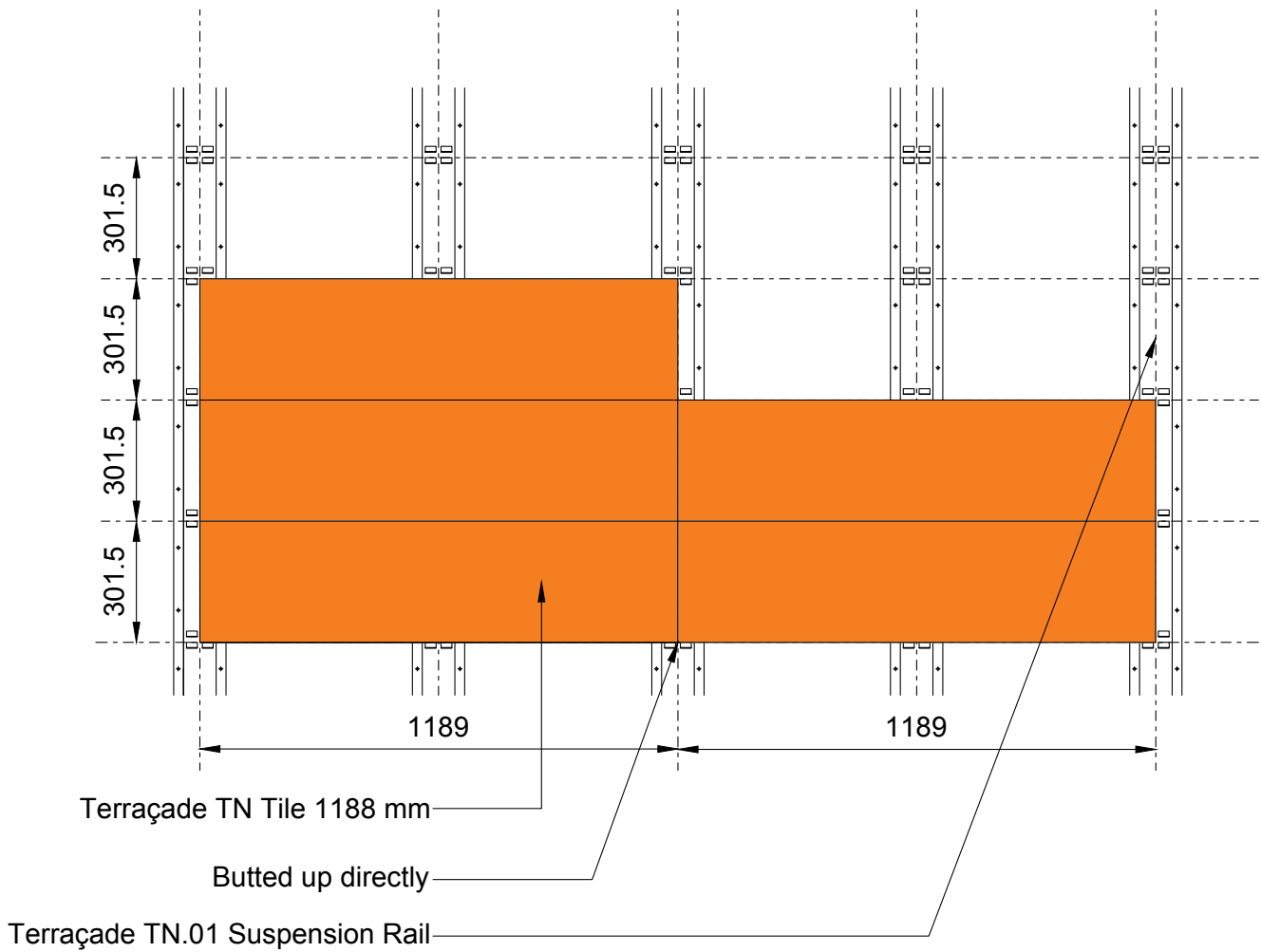

**ISSUE F-0122**

© Copyright 2022. Australian New Zealand Patent & Design Registrations. This drawing is indicative only and allowances should be made for material and onsite variations. The component and the assembly details demonstrate a design methodology only. Assembly and documentation drawings should only be undertaken after reference and compliance with the

relevant component's technical data. The diagram is not to scale. For more tailored solutions to suit individual applications, please contact Brickworks Building Products. Brickworks Building Products reserves the rights to add, alter or delete components without prior notice.

# SYSTEM DESCRIPTION

## *Terraçade TN System with Joint Channel*

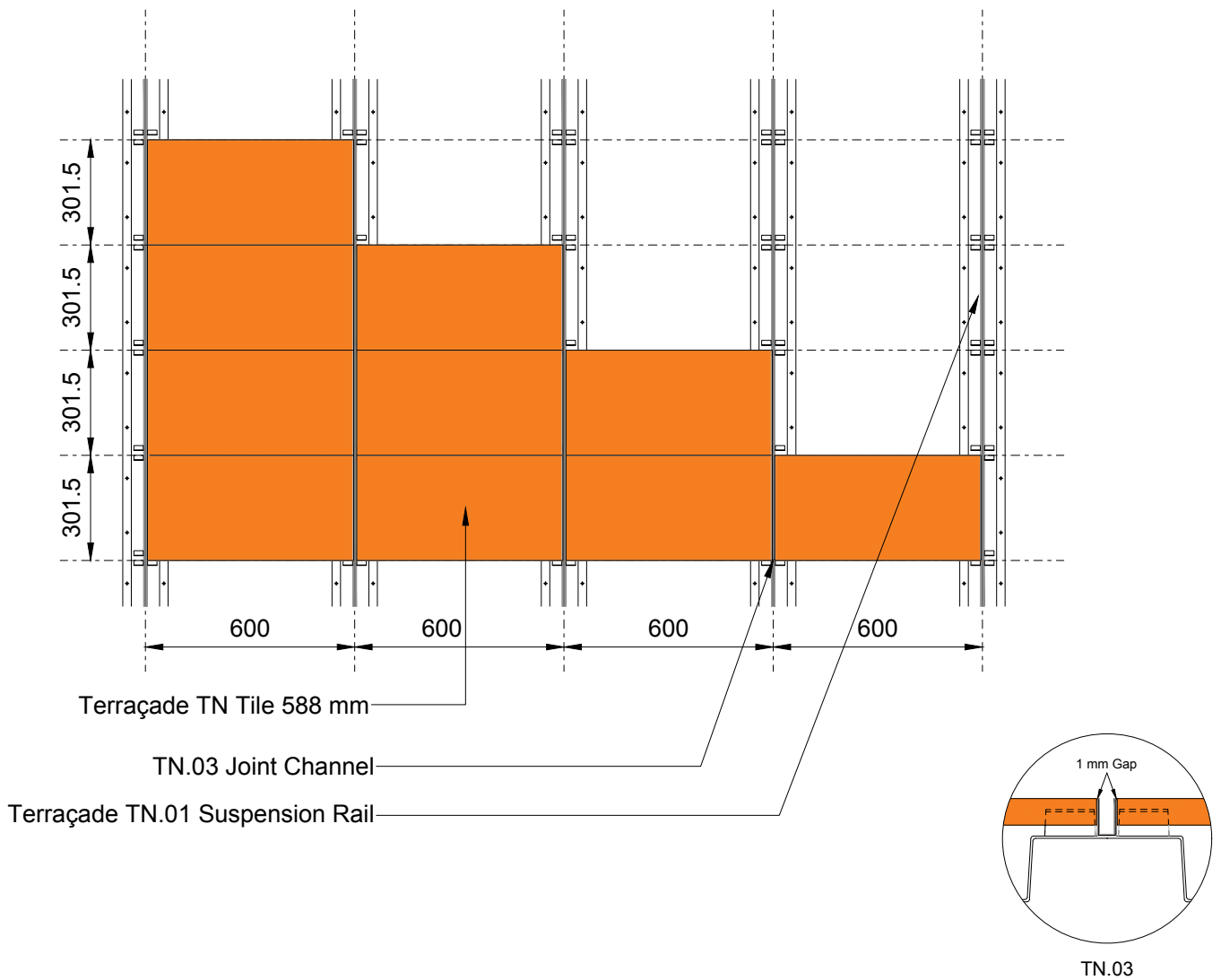

**ISSUE F-0122**

© Copyright 2022. Australian New Zealand Patent & Design Registrations. This drawing is indicative only and allowances should be made for material and onsite variations. The component and the assembly details demonstrate a design methodology only. Assembly and documentation drawings should only be undertaken after reference and compliance with the

relevant component's technical data. The diagram is not to scale. For more tailored solutions to suit individual applications, please contact Brickworks Building Products. Brickworks Building Products reserves the rights to add, alter or delete components without prior notice.

# SYSTEM DESCRIPTION

## *Terraçade TN System with Joint Channel*

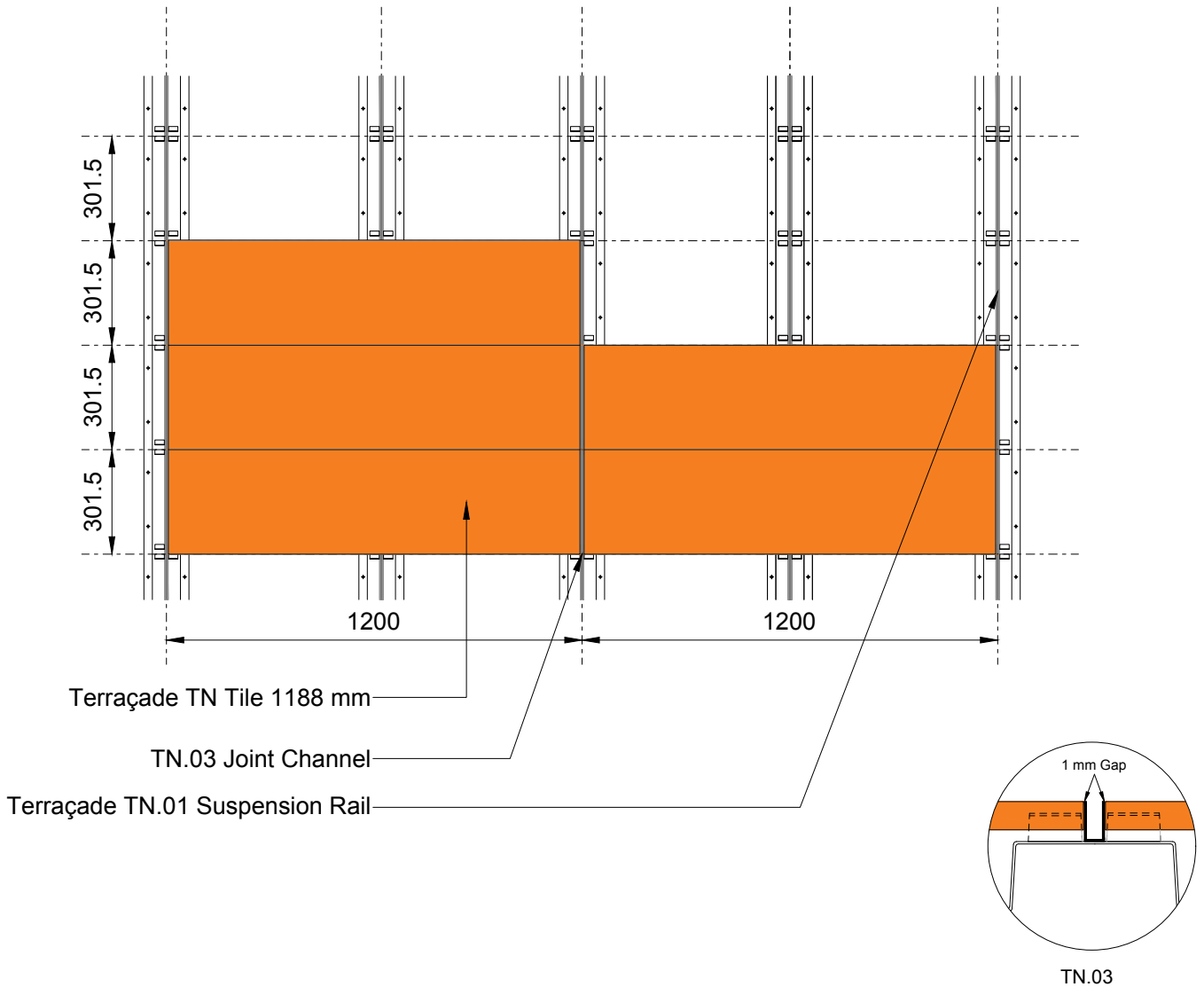

**ISSUE F-0122**

© Copyright 2022. Australian New Zealand Patent & Design Registrations. This drawing is indicative only and allowances should be made for material and onsite variations. The component and the assembly details demonstrate a design methodology only. Assembly and documentation drawings should only be undertaken after reference and compliance with the

relevant component's technical data. The diagram is not to scale. For more tailored solutions to suit individual applications, please contact Brickworks Building Products. Brickworks Building Products reserves the rights to add, alter or delete components without prior notice.

# SYSTEM DESCRIPTION

## *Terraçade TN System with Joint Angle*

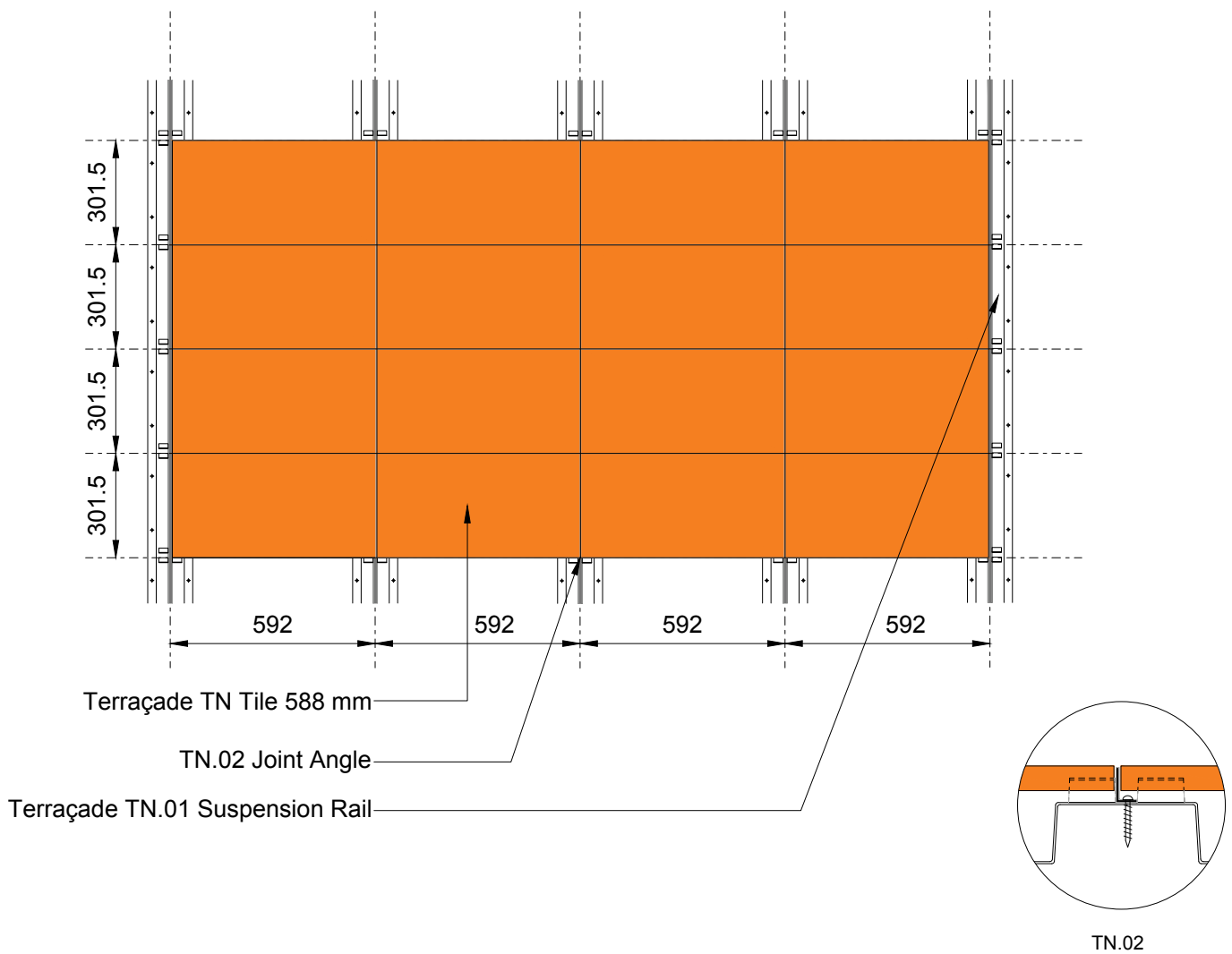

**ISSUE F-0122**

© Copyright 2022. Australian New Zealand Patent & Design Registrations. This drawing is indicative only and allowances should be made for material and onsite variations. The component and the assembly details demonstrate a design methodology only. Assembly and documentation drawings should only be undertaken after reference and compliance with the

relevant component's technical data. The diagram is not to scale. For more tailored solutions to suit individual applications, please contact Brickworks Building Products. Brickworks Building Products reserves the rights to add, alter or delete components without prior notice.

# SYSTEM DESCRIPTION

## *Terraçade TN System with Joint Angle*

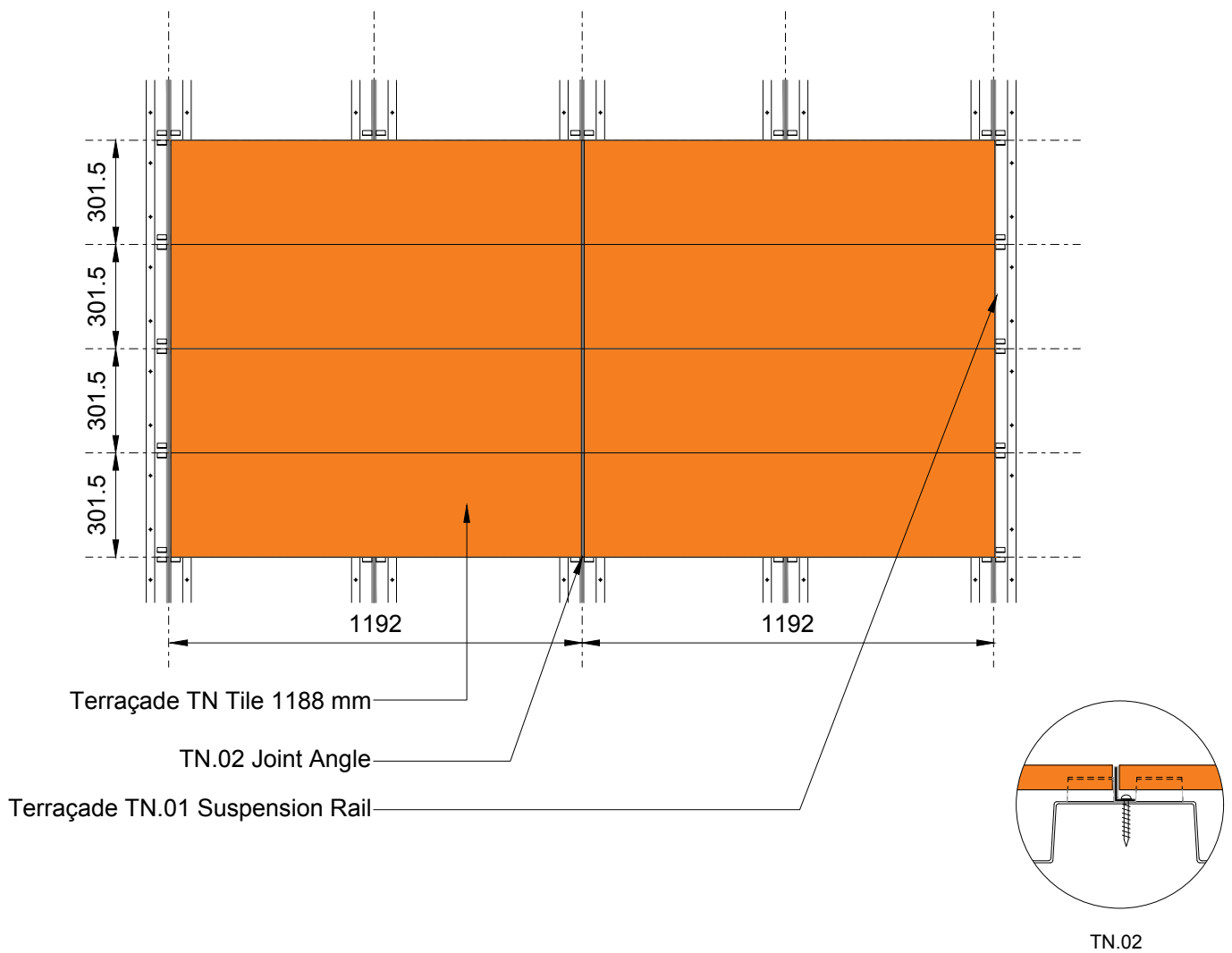

**ISSUE F-0122**

© Copyright 2022. Australian New Zealand Patent & Design Registrations. This drawing is indicative only and allowances should be made for material and onsite variations. The component and the assembly details demonstrate a design methodology only. Assembly and documentation drawings should only be undertaken after reference and compliance with the

relevant component's technical data. The diagram is not to scale. For more tailored solutions to suit individual applications, please contact Brickworks Building Products. Brickworks Building Products reserves the rights to add, alter or delete components without prior notice.

# SYSTEM DESCRIPTION

## *Terraçade TN System Side Profile*

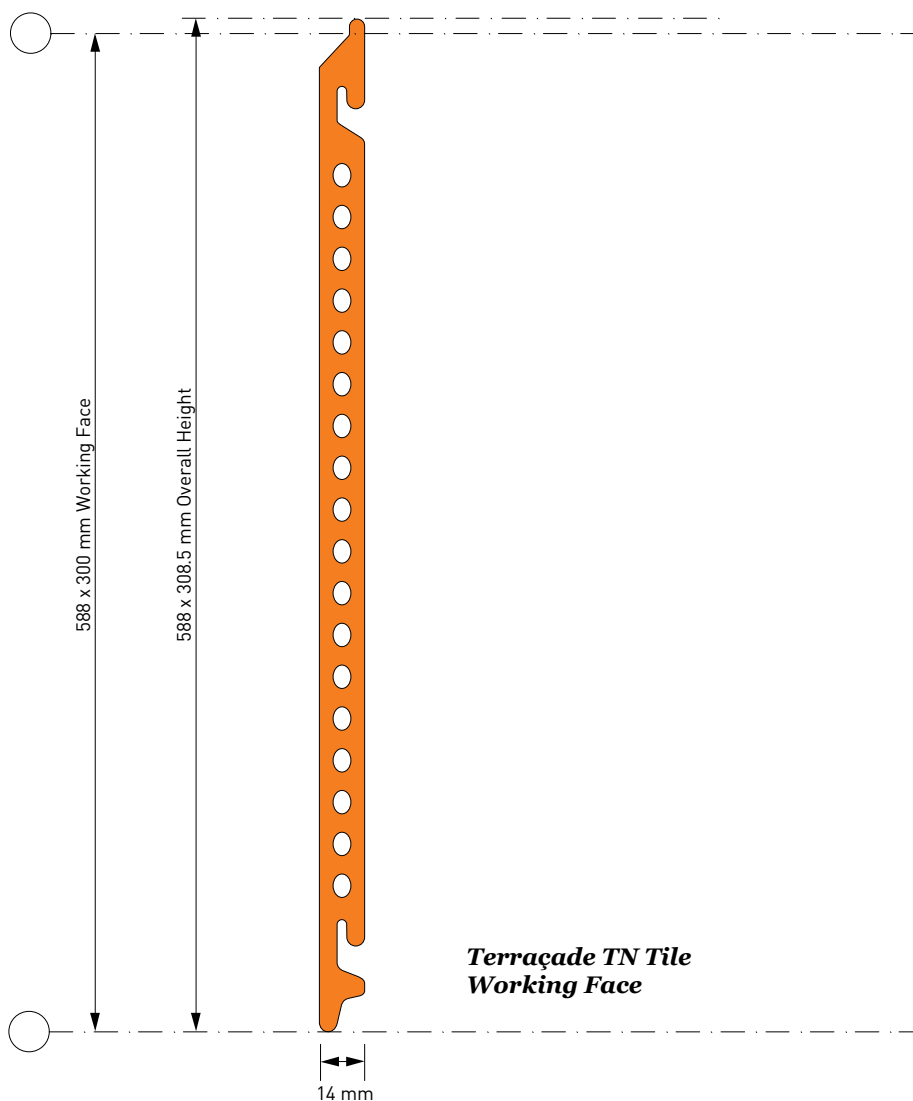

**ISSUE F-0122**

© Copyright 2022. Australian New Zealand Patent & Design Registrations. This drawing is indicative only and allowances should be made for material and onsite variations. The component and the assembly details demonstrate a design methodology only. Assembly and documentation drawings should only be undertaken after reference and compliance with the

relevant component's technical data. The diagram is not to scale. For more tailored solutions to suit individual applications, please contact Brickworks Building Products. Brickworks Building Products reserves the rights to add, alter or delete components without prior notice.

# STRUCTURAL PERFORMANCE

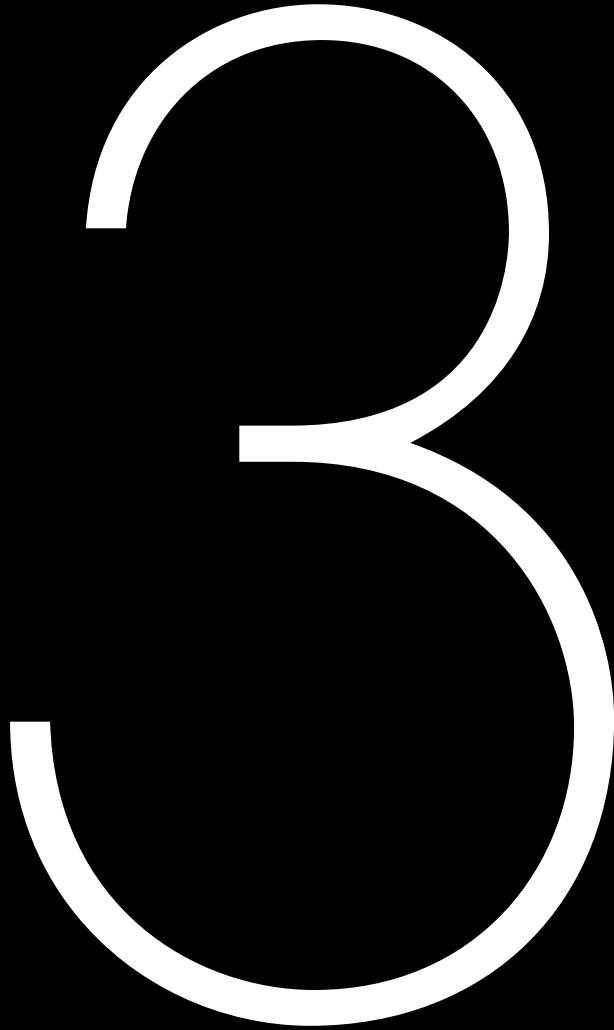

For the most up to date information on Terraçade products and the latest version of this manual, please refer to our website; [www.terraçade.com.au](http://www.terraçade.com.au)



# STRUCTURAL PERFORMANCE

## System Performance for Earthquake and Wind Loads

### Supply and Testing Statement

The Terraçade TN system has been tested to AS/NZS 4284 (Testing of building façades) for structural performance and has passed the deflection criteria under serviceable limit state.

System and structural advice has been obtained from Core Project Consulting (Australia) Pty. Ltd. and they have also provided engineering guidance on the structural testing.

### Earthquake Performance

The Terraçade TN system has been checked for compliance with NZS 1170.5-2004: Structural design actions - Earthquake actions in New Zealand for buildings of importance level 2 and a design life of 50 years in accordance with AS/NZS 1170.0-2002 Structural Design Actions.

From analysis of NZS 1170.5, Terraçade TN tiles may be used for buildings at any site with a hazard factor Z less than or equal to 0.6, for any subsoil class, when supported on suspension rails fixed to the structure in span configurations 3 to 8 inclusive. For span configurations 1 or 2, the maximum site hazard factor Z must be less than a specific limit (refer to span configuration table below).

The Terraçade TN systems develops forces on the support rails from the action of inertia during seismic events which are less than or equal to the maximum ultimate wind

pressure for each support rail fastener span configuration stated below. The horizontal directions of movement are accommodated by the inherent strength of the system. No further action is therefore necessary to resist such movements.

Movement in a true vertical direction requires restraint against the tiles lifting directly off the rail system under such an action. For installation in New Zealand, the Terraçade TN system requires an anti-lift block or trim installed along its top edge to ensure tiles are unable to detach from their supporting rail under the action of vertical seismic events.

When the anti-lift block or trim is installed, the system is suitable for installation against earthquakes in New Zealand. This precaution does not alleviate the system's requirements for installation against wind load.

*(Statement supplied by Core Project Consulting).*

Hazard Factor 'Z' Limit for Suspension Rails:

Span Configuration							
1	2	3	4	5	6	7	8
Galvanised Steel & ZAM® Coastal:							
0.38	0.47	0.6	0.6	0.6	0.6	0.6	0.6
Stainless Steel:							
0.23	0.31	0.6	0.6	0.6	0.6	0.6	0.6

\* Note: The arrows in the allowable pressures tables indicate the fastener locations and the distance noted is the span (mm) between the fasteners.

### Ultimate Wind Pressures

The following charts and tables have been calculated assuming a building consequence of failure importance level of 2 and a design life of 50 years in accordance with AS/NZS 1170.

Contact Brickworks Building Products for further engineering advice for buildings that are outside the above criteria.

The ultimate wind pressures have been calculated for both the standard (galvanised steel) and the coastal (ZAM® pre-coated steel and stainless steel) support rail versions; the pertinent table should be referred to for a particular project. The ultimate wind pressure tables have been characterised by a particular span configuration. The ultimate wind pressures listed refer to the span configuration directly above it.

The span configuration tables should be used in accordance with the fastener specifications given in the Technical Specification section. Design documentation should accommodate the ultimate wind pressures and fastener specifications for a particular project.

#### Ultimate Wind Pressures for the standard suspension rail (galvanised steel) & Coastal Suspension Rail (ZAM® Pre-Coated Steel).

Span Configurations for Terraçade TN							
1	2	3	4	5	6	7	8
Ultimate Wind Pressure (kPa) for Support Rails at 600 mm Centres:							
0.80	1.00	1.90	2.10	3.75	3.75	3.75	3.75
Maximum Reactions (permissible) kN:							
0.71	0.67	1.17	1.17	1.52	1.40	1.52	0.74

#### Ultimate Wind Pressures for the Coastal Suspension Rail (Stainless Steel).

Span Configurations for Terraçade TN							
1	2	3	4	5	6	7	8
Ultimate Wind Pressure (kPa) for 600 mm Centres:							
0.48	0.65	1.15	1.38	2.51	2.51	2.51	2.51
Maximum Reactions (permissible) kN:							
0.43	0.44	0.71	0.78	1.02	0.94	1.02	0.50

\* Note: The arrows in the allowable pressures tables indicate the fastener locations and the distance noted is the span (mm) between the fasteners.

# STRUCTURAL PERFORMANCE

## System Performance for Wind Loads

### Part A – Step-by-Step Method

#### Determining Span Configuration for Wind Load Requirements

The following wind load requirements on Terraçade TN only apply to buildings that comply with New Zealand Standard AS/NZS 1170.2 (Structural design actions, Part 2: Wind actions). The applicability of AS/NZS 1170.2 and subsequent compliance of individual projects should be verified.

AS/NZS 1170.2 identifies three wind regions pertinent to New Zealand as shown in the map. In addition, some projects will require a multiplying factor to be taken into consideration when located in an area affected by the Lee Multiplier (as shown in the map).

Two methods of determining the span configuration are available, depending on the information available on a particular project. Please apply the following checklist to each project to determine which method to use:

	Yes	No
Is the wind region known?	<input type="radio"/>	<input type="radio"/>
Is the terrain category known?	<input type="radio"/>	<input type="radio"/>
Is the height of the installation known?	<input type="radio"/>	<input type="radio"/>
The project is not affected by a Lee Multiplier?	<input type="radio"/>	<input type="radio"/>

(This information should be determined in accordance with AS/NZS 1170.2)

If all of these answers were “Yes” then please use the tables provided on pages 22 and 24 (Specialised Engineering Method) to quickly determine the span configuration. If any of these answers were “No” then please use the following Step-by-Step Method. It is especially important that any projects located in an area affected by the Lee Multiplier use the Step-by-Step Method.

**Note:** Shielding was not considered in the analysis.

**Note:** Topography can affect wind pressure if a building is located high on a steep slope or escarpment. Brickworks Building Products should be contacted in such circumstances.

#### Step-By-Step Method

Leading engineers at Core Project Consulting have considered the wind pressure requirements for Terraçade TN and have derived the following procedure for determining the minimum span configurations required.

##### Step A1: Wind Region

Identify the wind region that the project is located in. If the wind region has not been specified, it should be determined in accordance with AS/NZS 1170.2. Please note whether the particular project falls into an area affected by a Lee Multiplier.

##### Step A2: Height

Determine the height the Terraçade TN will be installed above the ground level. AS/NZS 1170.2 outlines the method of determining reference heights.

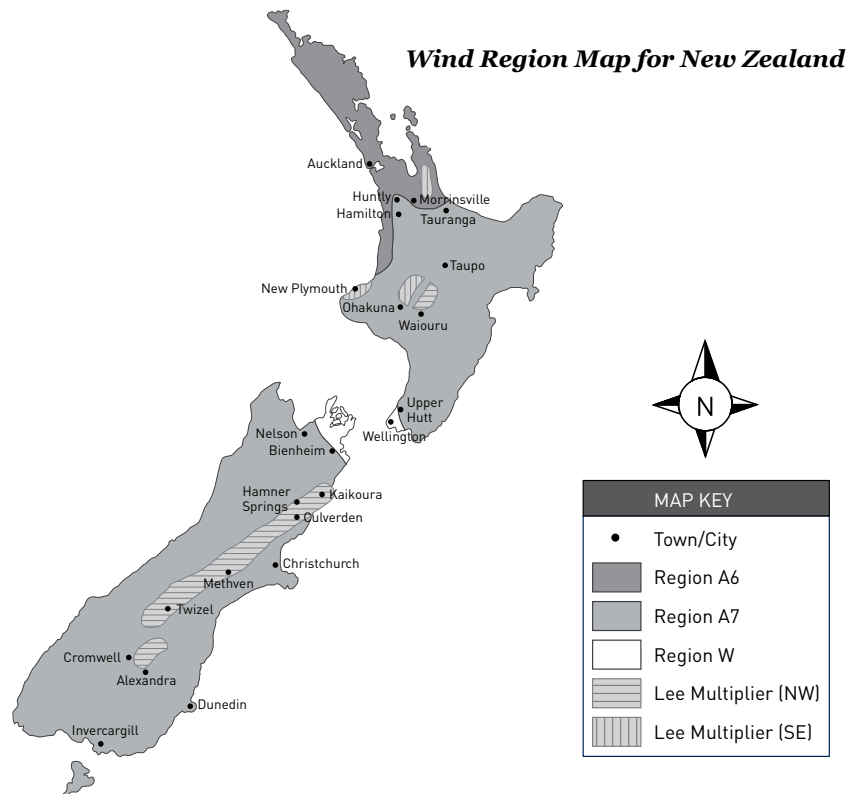

# STRUCTURAL PERFORMANCE

## System Performance for Wind Loads

### Part A – Step-by-Step Method

#### Step A3: Terrain Category

Identify the terrain category for the project. The terrain affects the wind flows that a project is subjected to. The four terrain categories defined in AS/NZS 1170.2 are:

- **Category 1:** Very few or no obstructions and an exposed open terrain.
- **Category 1.5:** Open water surfaces subjected to shoaling waves, e.g. near-shore ocean water; large unenclosed bays on seas and oceans; lakes; and enclosed bays extending greater than 10 km in the wind direction.
- **Category 2:** Limited and well-spread obstructions in an open terrain. Typical terrains include grasslands and water surfaces.
- **Category 2.5:** Terrain with a few trees or isolated obstructions, typical of developing outer urban areas with scattered houses, or large acreage developments with fewer than ten buildings per hectare.
- **Category 3:** Numerous low (3-5 m) obstructions that are closely spaced. A typical terrain is a suburban housing estate.
- **Category 4:** High number of large and tall (10-30 m) obstructions that are closely spaced. A typical terrain is a large city centre.

**Note:** The terrain category should be determined in accordance with AS/NZS 1170.2 and obstructions should have permanence during a wind event.

#### Step A4: Wind Pressure

Use the wind pressure table (refer to Table A1 on page 22) to determine the wind pressure for the individual characteristics determined. Always select the limiting height that is larger or equal to the project installation height.

#### Example 1:

A typical project in a suburban area (Terrain Category 3) in Wellington is in the W region. If the project is installed to a height of 4 m, the 5 m limiting height column should be used. The ultimate wind pressure for Terraçade TN in this case is 1.33 kPa (using Table A1 on page 22).

#### Step A5: Corner Wind Pressure

The corners of tall, slender buildings experience higher wind pressures than the rest of the building. When Terraçade TN is installed in this corner region, a different support rail span configuration may be required.

To determine the span configuration requirement, calculate the aspect ratio ( $r$ ) of the building by dividing its average roof height ( $h$ ) by its smallest plan dimension ( $b$  or  $d$ ). If the aspect ratio is less than or equal to 1, no additional requirements are necessary for Terraçade TN being installed on the building corner. (Note: AS/NZS 1170.2-2011 has equalised the worst-case magnitudes of positive and negative wind pressure coefficients and factors for permeable cladding on buildings with an aspect ratio of less than or equal to 1).

If the aspect ratio is greater than 1, then check whether any Terraçade TN is being installed on the building corners. The length of the corner region (for a tall building) is one-tenth of the shortest plan dimension (refer to below diagram).

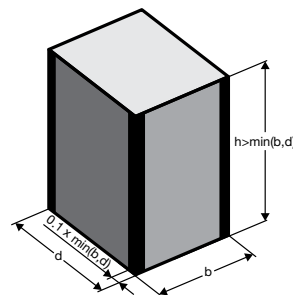

#### Example 2:

A six storey building has plan dimensions of 32 metres and 16 metres, and has an average roof height of 20 metres. The aspect ratio found by dividing the height of 20 m by the smallest plan dimension i.e., 16 m, which equals 1.25. Since the aspect ratio is greater than 1, additional fixings for the Terraçade TN support rails are required at the corners of the building for the increased wind pressure.

The distance from the corners of the building requiring additional fixings for the Terraçade TN support rails is one-tenth of the shortest plan dimension, which in this example is  $0.1 \times 16 = 1.6$  metres. This must be rounded up to a multiple of 600 mm (support rail spacing), for this example, the distance from the corners of the building requiring additional support fixings is 1.8 m for 600 mm wide Terraçade TN panels of 2.4 m for 1200 mm panels.

#### Example 3:

A typical project in a suburban area (Terrain Category 3) in Wellington is in the W region. If the project is installed to a height of 4 m, the 10 m limiting height column should be used. The ultimate wind pressure for Terraçade TN in general use is 1.33 kPa (using Table A1 on page 22) and the ultimate wind pressure on a corner is 1.90 kPa (using Table A2 on page 23).

# STRUCTURAL PERFORMANCE

## *System Performance for Wind Loads*

### *Part A – Step-by-Step Method*

#### **Step A6: Span Determination**

If the project is located in a Lee Multiplier area (as identified from the wind region map) an additional factor of 1.35 must be applied to the wind pressure for Terraçade TN (for both the general pressure and the corner pressure).

#### **Example 4:**

For a project in a Lee Multiplier region with an ultimate wind pressure of 1.33 kPa in general areas, the adjusted wind pressure is  $1.35 \times 1.33 \text{ kPa} = 1.80 \text{ kPa}$ . The ultimate wind pressure for building corners of 1.90 kPa, when adjusted is  $1.35 \times 1.90 \text{ kPa} = 2.57 \text{ kPa}$ .

#### **Step A7: Span Determination**

To determine the span configuration from the wind pressures found in the preceding steps, use the tables in the Ultimate Wind Pressures section. The span configuration tables show the ultimate wind pressure of the Terraçade TN system at different span configurations. Using the wind pressure determined, identify the span configuration that has a greater ultimate wind pressure than the requirement. If Terraçade TN is to be installed at a corner, the span configuration for this situation should also be determined. It is important to remember that particular projects within C5 Corrosion Zone, require the coastal version stainless steel rails and therefore should use the Span Configuration chart on page 17.

The span configurations determined should be specified along with the fastener requirements (refer to the Technical Specifications – Fasteners Section) in all project documentation.

Check span configurations for earthquake site hazard factor 'Z' limits (refer table on page 16).

#### **Example 5:**

A typical low-rise project in a suburban area (Terrain Category 3) in New Plymouth is in the A7 region and has a Lee Multiplier of 1.35. If the project is installed at a height of 4m the ultimate wind pressure for Terraçade TN in this case is  $1.03 \text{ kPa} \times 1.35 = 1.39 \text{ kPa}$ . The aspect ratio is found to be less than 1, so no change in the span configuration is required (from Steps A4 and A5). If the coastal version stainless steel rail is required then using the ultimate wind pressure for the Coastal Version table on page 17, the required span configuration is Span 5 (or greater) for all areas of the building.

# STRUCTURAL PERFORMANCE

## *System Performance for Wind Loads*

### *Part A – Step-by-Step Method*

Table A1: Wind Pressure.

Wind Region	Limiting Height (m)	Terrain Category 1	Terrain Category 1.5	Terrain Category 2	Terrain Category 2.5	Terrain Category 3	Terrain Category 4
A6	10	1.88	1.69	1.50	1.26	1.03	0.84
	15	2.01	1.83	1.65	1.42	1.19	0.84
	20	2.12	1.93	1.75	1.53	1.32	0.84
	30	2.23	2.05	1.88	1.69	1.50	0.96
	40	2.30	2.16	2.01	1.82	1.62	1.08
A7	10	1.88	1.69	1.50	1.26	1.03	0.84
	15	2.01	1.83	1.65	1.42	1.19	0.84
	20	2.12	1.93	1.75	1.53	1.32	0.84
	30	2.23	2.05	1.88	1.69	1.50	0.96
	40	2.30	2.16	2.01	1.82	1.62	1.08
W	10	2.42	2.18	1.93	1.63	1.33	1.09
	15	2.60	2.36	2.13	1.83	1.53	1.09
	20	2.73	2.49	2.25	1.98	1.71	1.09
	30	2.87	2.65	2.42	2.18	1.93	1.24
	40	2.97	2.78	2.60	2.34	2.09	1.39

# STRUCTURAL PERFORMANCE

## *System Performance for Wind Loads*

### *Part A – Step-by-Step Method*

Table A2: Wind Pressure for Tall Building Corners (Aspect Ratio > 1).

Wind Region	Limiting Height (m)	Terrain Category 1	Terrain Category 1.5	Terrain Category 2	Terrain Category 2.5	Terrain Category 3	Terrain Category 4
A6	10	2.68	2.41	2.14	1.80	1.47	1.20
	15	2.87	2.61	2.35	2.02	1.69	1.20
	20	3.02	2.76	2.49	2.19	1.89	1.20
	30	3.18	2.93	2.68	2.41	2.14	1.37
	40	3.28	3.08	2.87	2.59	2.31	1.54
A7	10	2.68	2.41	2.14	1.80	1.47	1.20
	15	2.87	2.61	2.35	2.02	1.69	1.20
	20	3.02	2.76	2.49	2.19	1.89	1.20
	30	3.18	2.93	2.68	2.41	2.14	1.37
	40	3.28	3.08	2.87	2.59	2.31	1.54
W	10	3.45	3.10	2.75	2.33	1.90	1.55
	15	3.71	3.37	3.04	2.61	2.18	1.55
	20	3.90	3.56	3.21	2.82	2.43	1.55
	30	4.10	3.78	3.45	3.10	2.75	1.76
	40	4.23	3.97	3.71	3.34	2.98	1.99





# STRUCTURAL PERFORMANCE

## *Part B – Specialised Engineering Method*

Table B1: General Installation (ZAM® pre-coated steel or galvanised rail).

Wind Region	Limiting Height (m)	Terrain Category 1	Terrain Category 1.5	Terrain Category 2	Terrain Category 2.5	Terrain Category 3	Terrain Category 4
A7	10	Span 3	Span 3	Span 3	Span 3	Span 3	Span 2
	15	Span 4	Span 3	Span 3	Span 3	Span 3	Span 2
	20	Span 5-8	Span 4	Span 3	Span 3	Span 3	Span 2
	30	Span 5-8	Span 4	Span 3	Span 3	Span 3	Span 2
	40	Span 5-8	Span 5-8	Span 4	Span 3	Span 3	Span 3
A8	10	Span 3	Span 3	Span 3	Span 3	Span 3	Span 2
	15	Span 4	Span 3	Span 3	Span 3	Span 3	Span 2
	20	Span 5-8	Span 4	Span 3	Span 3	Span 3	Span 2
	30	Span 5-8	Span 4	Span 3	Span 3	Span 3	Span 2
	40	Span 5-8	Span 5-8	Span 4	Span 3	Span 3	Span 3
W	10	Span 5-8	Span 5-8	Span 4	Span 3	Span 3	Span 3
	15	Span 5-8	Span 5-8	Span 5-8	Span 3	Span 3	Span 3
	20	Span 5-8	Span 5-8	Span 5-8	Span 4	Span 3	Span 3
	30	Span 5-8	Span 5-8	Span 5-8	Span 5-8	Span 4	Span 3
	40	Span 5-8	Span 5-8	Span 5-8	Span 5-8	Span 4	Span 3

Table B2: Corner Installation for Aspect Ratio  $>1$  (ZAM® pre-coated steel or galvanised rail).

Wind Region	Limiting Height (m)	Terrain Category 1	Terrain Category 1.5	Terrain Category 2	Terrain Category 2.5	Terrain Category 3	Terrain Category 4
A7	10	Span 5-8	Span 5-8	Span 5-8	Span 3	Span 3	Span 3
	15	Span 5-8	Span 5-8	Span 5-8	Span 4	Span 3	Span 3
	20	Span 5-8	Span 5-8	Span 5-8	Span 5-8	Span 3	Span 3
	30	Span 5-8	Span 5-8	Span 5-8	Span 5-8	Span 5-8	Span 3
	40	Span 5-8	Span 5-8	Span 5-8	Span 5-8	Span 5-8	Span 3
A8	10	Span 5-8	Span 5-8	Span 5-8	Span 3	Span 3	Span 3
	15	Span 5-8	Span 5-8	Span 5-8	Span 4	Span 3	Span 3
	20	Span 5-8	Span 5-8	Span 5-8	Span 5-8	Span 3	Span 3
	30	Span 5-8	Span 5-8	Span 5-8	Span 5-8	Span 5-8	Span 3
	40	Span 5-8	Span 5-8	Span 5-8	Span 5-8	Span 5-8	Span 3
W	10	Span 5-8	Span 5-8	Span 5-8	Span 5-8	Span 3	Span 3
	15	Span 5-8	Span 5-8	Span 5-8	Span 5-8	Span 5-8	Span 3
	20	N/A	Span 5-8	Span 5-8	Span 5-8	Span 5-8	Span 3
	30	N/A	N/A	Span 5-8	Span 5-8	Span 5-8	Span 3
	40	N/A	N/A	Span 5-8	Span 5-8	Span 5-8	Span 4

\*N/A equals Not Available.

# STRUCTURAL PERFORMANCE

## *Part B – Specialised Engineering Method*

### **Coastal Version**

Table B3: General Installation (Stainless Steel Rails).

Wind Region	Limiting Height (m)	Terrain Category 1	Terrain Category 1.5	Terrain Category 2	Terrain Category 2.5	Terrain Category 3	Terrain Category 4
A7	10	Span 5-8	Span 5-8	Span 5-8	Span 4	Span 3	Span 3
	15	Span 5-8	Span 5-8	Span 5-8	Span 5-8	Span 4	Span 3
	20	Span 5-8	Span 5-8	Span 5-8	Span 5-8	Span 4	Span 3
	30	Span 5-8	Span 5-8	Span 5-8	Span 5-8	Span 5-8	Span 3
	40	Span 5-8	Span 5-8	Span 5-8	Span 5-8	Span 5-8	Span 3
A8	10	Span 5-8	Span 5-8	Span 5-8	Span 4	Span 3	Span 3
	15	Soab 5-8	Span 5-8	Span 5-8	Span 5-8	Span 4	Span 3
	20	Span 5-8	Span 5-8	Span 5-8	Span 5-8	Span 4	Span 3
	30	Span 5-8	Span 5-8	Span 5-8	Span 5-8	Span 5-8	Span 3
	40	Span 5-8	Span 5-8	Span 5-8	Span 3	Span 5-8	Span 3
W	10	Span 5-8	Span 5-8	Span 5-8	Span 5-8	Span 4	Span 3
	15	N/A	Span 5-8	Span 5-8	Span 5-8	Span 5-8	Span 3
	20	N/A	Span 5-8	Span 5-8	Span 5-8	Span 5-8	Span 3
	30	N/A	N/A	Span 5-8	Span 5-8	Span 5-8	Span 4
	40	N/A	N/A	N/A	Span 5-8	Span 5-8	Span 5-8

\*N/A equals Not Available.

Table B4: Corner Installation for Aspect Ratio >1 (Stainless Steel Rails).

Wind Region	Limiting Height (m)	Terrain Category 1	Terrain Category 1.5	Terrain Category 2	Terrain Category 2.5	Terrain Category 3	Terrain Category 4
A7	10	N/A	Span 5-8	Span 5-8	Span 5-8	Span 5-8	Span 4
	15	N/A	N/A	Span 5-8	Span 5-8	Span 5-8	Span 4
	20	N/A	N/A	Span 5-8	Span 5-8	Span 5-8	Span 4
	30	N/A	N/A	N/A	Span 5-8	Span 5-8	Span 4
	40	N/A	N/A	N/A	N/A	Span 5-8	Span 5-8
A8	10	N/A	Span 5-8	Span 5-8	Span 5-8	Span 5-8	Span 4
	15	N/A	N/A	Span 5-8	Span 5-8	Span 5-8	Span 4
	20	N/A	N/A	Span 5-8	Span 5-8	Span 5-8	Span 4
	30	N/A	N/A	N/A	Span 5-8	Span 5-8	Span 4
	40	N/A	N/A	N/A	N/A	Span 5-8	Span 5-8
W	10	N/A	N/A	N/A	Span 5-8	Span 5-8	Span 5-8
	15	N/A	N/A	N/A	N/A	Span 5-8	Span 5-8
	20	N/A	N/A	N/A	N/A	Span 5-8	Span 5-8
	30	N/A	N/A	N/A	N/A	N/A	Span 5-8
	40	N/A	N/A	N/A	N/A	N/A	Span 5-8

\*N/A equals Not Available.





# TECHNICAL SPECIFICATIONS

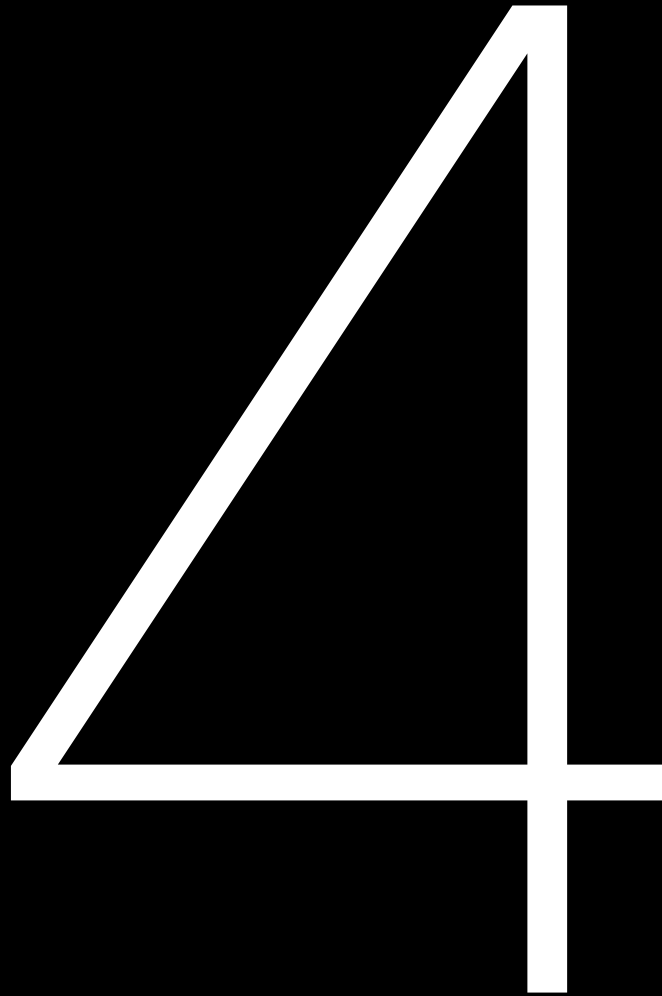

For the most up to date information on Terraçade products and the latest version of this manual, please refer to our website; [www.terraçade.com.au](http://www.terraçade.com.au)

# TECHNICAL SPECIFICATIONS

## *Materials Schedule and Properties*

A list of the materials used in the Terraçade TN system is given below.

Component	Material
01. Tiles	Fired extruded clay tile.
02. Suspension Rail	Standard - Galvanised (cold formed light galvanised sheet), or C4 Coastal - ZAM® pre-coated steel, or C5 Coastal - stainless steel sheet grade 316.
03. Visible Trims	Aluminium - All extrusions are aluminium Grade 6063-T5 and are produced to AS/NZS 1866 (Aluminium and Aluminium Alloy - Extruded Rod, Bar, Solid and Hollow Shapes). Trims are available in: <ul style="list-style-type: none"> <li>• Mill finish, which is expected to have a design life in excess of twenty-five years for moderate environments (as defined in AS/NZS 2312).</li> <li>• Anodised finish in clear and black, which can have a design life in excess of forty years.</li> <li>• Powder coated finish to AS/NZS 3715 in various colours, which can come with a guarantee of ten years.</li> </ul> Folded Metal Trims – These trims are available in Colourbond® or alternative finishes from other suppliers.
04. Waterproof Membrane	As part of the Terraçade system for framed installation a waterproof membrane equivalent to or exceeding the Vaproshield RevealShield SA (self adhered) WRB (water resistive barrier) Membrane System needs to be installed over 6 mm RAB (rigid air barrier) or similar.
05. Fitment Sponge	EPDM rubber with acrylic adhesive.
06. Anti-Lifting Block	Polyoelfin foam with adhesive.
07. Set-out Tool	Specially designed tool to maintain vertical continuity if multiple lengths of the suspension rail are butted end to end.

### **Tile Properties:**

Extensive testing is carried out in Austral Bricks' NATA accredited laboratory to AS/NZS 4459, AS/NZS 4456, and in independent NATA accredited laboratories to ISO 10545.

(Nominal) Tile Dimensions	308 x 588 mm	308 x 1188 mm
Mass	~4.5 kg	~9 kg
Number of Tiles/m <sup>2</sup>	5.6	2.7
Weight/m <sup>2</sup>	25 kg	25 kg
Cold Water Absorption	<2.5%	<2.5%
Breaking Strength	~6.7 kN	~6.0 kN
Modulus of Rupture	~40 MPa	~44 MPa
Moisture Expansion	0.001%	0.001%
Linear Thermal Expansion	~4.8 x 10 <sup>-6</sup> (°C) <sup>-1</sup>	~4.8 x 10 <sup>-6</sup> (°C) <sup>-1</sup>
Durability Class	Exposure Grade	Exposure Grade
Fire Rating	Non-combustible	Non-combustible

\* Brickworks Building Products reserves the right to change specifications without notice – January 2022. Check the Terraçade website for updated results. ZAM® is a registered trademark of Nisshin Steel.

### ***Suspension Rail and Trim Options***

A table of the standard properties of the suspension rail and trim materials is given below.

	Nominal Length	Coefficient of Thermal Expansion ( $\times 10^{-6}/^{\circ}\text{C}$ )	I <sub>yy</sub> (mm <sup>4</sup> )	E (GPa)
Stainless Steel Suspension Rails	2700 mm	15.9 - 17.2	4.75x10 <sup>4</sup>	190
Galvanised Suspension Rails	2700 mm	11.7	4.75x10 <sup>4</sup>	200
ZAM® Pre-Coated Steel Suspension Rails	2700 or 3000 mm	10.7	4.75x10 <sup>4</sup>	210
Aluminium Trim	3600 and 5500 mm	23.4	-	69

Please ensure to create sufficient gaps between rails and trims to accommodate thermal expansion of the materials. For details on gaps refer page 69.

### ***Suspension Rail Selection Guide***

The suspension rail should be determined according to the atmospheric corrosivity of the site.

Distance from Breaking Surf*	Distance from Calm Salt Water Body, eg. Bay*	Corrosion Zone according to AS/NZS 4312	Recommended Suspension Rail Material
1001 m	101 m+	Up to C3	Galvanised
501 to 1000 m	0 to 100 m	Up to C4	ZAM® Pre-Coated Steel
0 to 500 m	0 to 100 m	Up to C5	304/316 Stainless Steel

\* General guide only. Please refer to AS/NZS 4312 for detailed corrosion zones.

### ***Fitment Sponge and Anti-Lifting Block Properties***

The properties of the sponge and anti-lifting block are given below.

Alternate materials can be used where properties are equivalent to, or exceed those in the table below.

	Fitment Sponge	Anti-Lifting Block
Dimensions	30 x 15 x 12 mm	100 x 30 x 10 mm
Cell Type	Closed	Closed
Water Penetration	0.07 mg/cm <sup>2</sup>	0.2 mg/cm <sup>2</sup>
Tear Strength	1.5 kg/cm	1.63 kg/cm
UV Resistance	Excellent	Good
Chemical Resistance	Good	Excellent
Compressive Strength	34.3 kPa	30 kPa
Elongation	158%	125%
Tensile Strength	255 kPa	270 kPa

# TECHNICAL SPECIFICATIONS

## *Fasteners*

The fasteners specified below should be used in accordance with the allowable pressures of the system.  
Design documentation should accommodate the allowable pressures and fastener specifications for a particular project.

Substrate	Fixings	Size	Recommended Min. Embedment	Grade
Timber	Type 17 Hex Head Screw	14 - 10 x 55 mm	Min. 45mm into supporting timber	SS 304
		12 - 11 x 55 mm		Class 4
Metal	Hex Head Bolt	M8 x 30 mm	Min. thickness of base plate 1 mm	SS 304
		M8 x 150 mm		SS 304
		M8 x 35 mm		SS 304
		M8 x 150 mm		SS 304
	Hex Head Tek Screw	14G x 50 mm		SS 304
Concrete Walls	Chemical Bolt	M10 x 130 mm	Min. 60 mm embedment depth	SS 316
		M8 x 110 mm		SS 316
		Chemset 101		SS 316
	Sleeve Anchor	6.5G x 55 mm	Min. 50 mm embedment depth	SS 316
				SS 316
Solid / Pressed Brick	Wall Plug + Screw	M8 x 50 mm plug + 14G x 50 mm screw	Min. 50 mm embedment depth	SS 304
Concrete Filled Hollow Block	Chemical Bolt	M10 x 130 mm	Min. 65 mm embedment depth	SS 316
		M8 x 110 mm		SS 316
		Chemset 101		
	Sleeve Anchor	M8 x 65 mm M8 x 80 mm	Min. 35 mm embedment depth	SS 316
				SS 316
Extruded Hollow Brick	Chemical Bolt	M10 x 130 mm	Min. 65 mm embedment depth	SS 316
		M8 x 110 mm		SS 316
		Chemset 101		
Fixing TN.02 Joint Angle to TN.01 Suspension Rail	Pan head self tapping screw	6G x 12 mm (min)		SS 304
Fixing TN.03 Joint Channel to TN.01 Suspension Rail	Rivet	4 mm x 8.9 mm		Aluminium

The above table is a guide to anchorage selection and does not alleviate the installers' responsibility to ensure the anchorage chosen is fit for purpose. Specifiers should review the maximum reaction section of the load span tables and review the design accordingly. If in doubt advice should be sought by the product design engineers.

All screws and bolts are to be manufactured to AS/NZS 1111 and AS/NZS 3566.

\* Note: Refer to the load span table (allowable pressures) for reaction output.

# TECHNICAL SPECIFICATIONS

## *System Performance*

### **Acoustic Performance**

The acoustic performances for particular wall constructions have been calculated by professional engineers from Hyder Consulting (Australia) Pty Ltd. The table below lists the weighted sound reduction value (R<sub>w</sub>) for the wall constructions.

Back Up Wall	Acoustic Performance (R <sub>w</sub> )
Lapped and taped sarking on timber stud wall with 50 mm insulation and 12 mm internal gyprock	41
Lightweight comprising 1.0 mm zincanneal sheet externally on 100 mm deep metal stud with 50 mm insulation on 6 mm internal gyprock sheet	44
110 mm thick solid masonry blockwork with 12 mm internal render	47
190 mm thick hollow concrete blockwork with 12 mm internal render	47

### **Thermal Resistance**

The thermal resistance (R-value) values for particular wall constructions have been calculated by professional engineers from Hyder Consulting (Australia) Pty Ltd. The table below lists the R-value for the wall constructions.

Back Up Wall	Overall U-Value (W/m <sup>2</sup> .K)	Overall R-Value (W/m <sup>2</sup> .K)
Lapped and taped sarking on timber stud wall with 50 mm insulation and 12 mm internal gyprock.	0.55	1.81
Lightweight comprising 1.0 mm zincanneal sheet externally on 100 mm deep metal stud with 50 mm insulation on 6 mm internal gyprock sheet	0.55	1.81
110 mm thick solid masonry blockwork with 12 mm internal render	2.05	0.49
190 mm thick hollow concrete blockwork with 12 mm internal render	1.73	0.58



# COMPONENTS

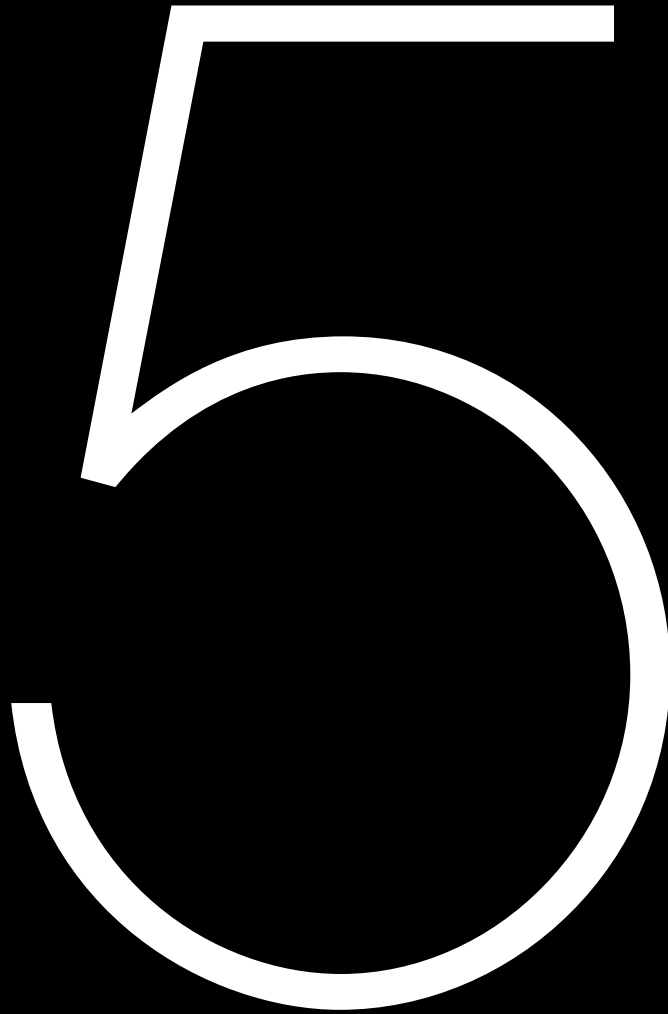

For the most up to date information on Terraçade products and the latest version of this manual, please refer to our website; [www.terraçade.com.au](http://www.terraçade.com.au)

# COMPONENTS

Comment Description	Page Number	Available from Terraçada
Terraçada™ TN Tile	35	Yes
TN. 01 Vertical Suspension Rail	36 & 37	Yes
<b>Joint Options</b>		
TN. 02 Aluminium Joint Angle	38	Yes
TN. 03 Aluminium Joint Channel	38	Yes
<b>Corner Trim Options</b>		
TN. 05 Aluminium Internal Corner	38	Yes
TN. 07 Aluminium Modified External Corner	38	Yes
<b>Surround Trim Options</b>		
TN. 09 Aluminium Standard Surround Profile	38	Yes
<b>Other Components</b>		
TN. E2 Fitment Sponge	39	Yes
TN. E4 Anti-Lifting Block	39	No
Rail Setting Tool	39	Yes

# COMPONENTS

## *Terraçade TN Tile Profile*

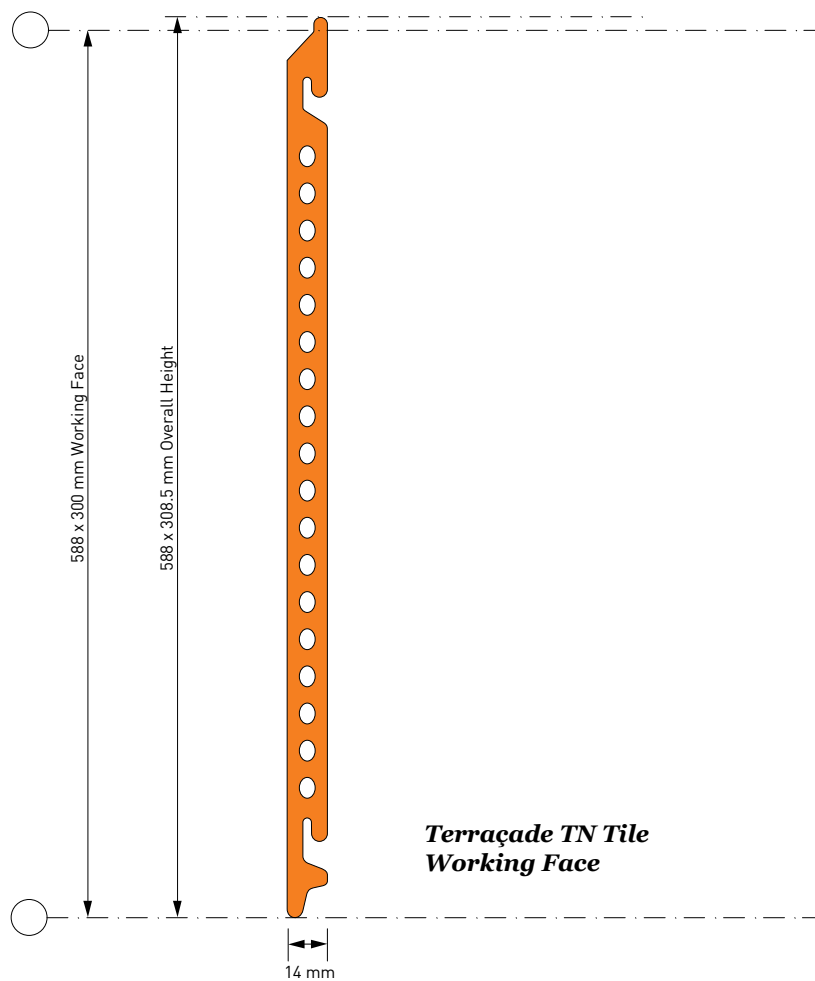

General tolerances for tiles: +/- 1% on all dimensions.

### ISSUE F-0122

© Copyright 2022. Australian New Zealand Patent & Design Registrations. This drawing is indicative only and allowances should be made for material and onsite variations. The component and the assembly details demonstrate a design methodology only. Assembly and documentation drawings should only be undertaken after reference and compliance with the

relevant component's technical data. The diagram is not to scale. For more tailored solutions to suit individual applications, please contact Brickworks Building Products. Brickworks Building Products reserves the rights to add, alter or delete components without prior notice.

# COMPONENTS

## *Terraçade TN Suspension Rail – Elevation*

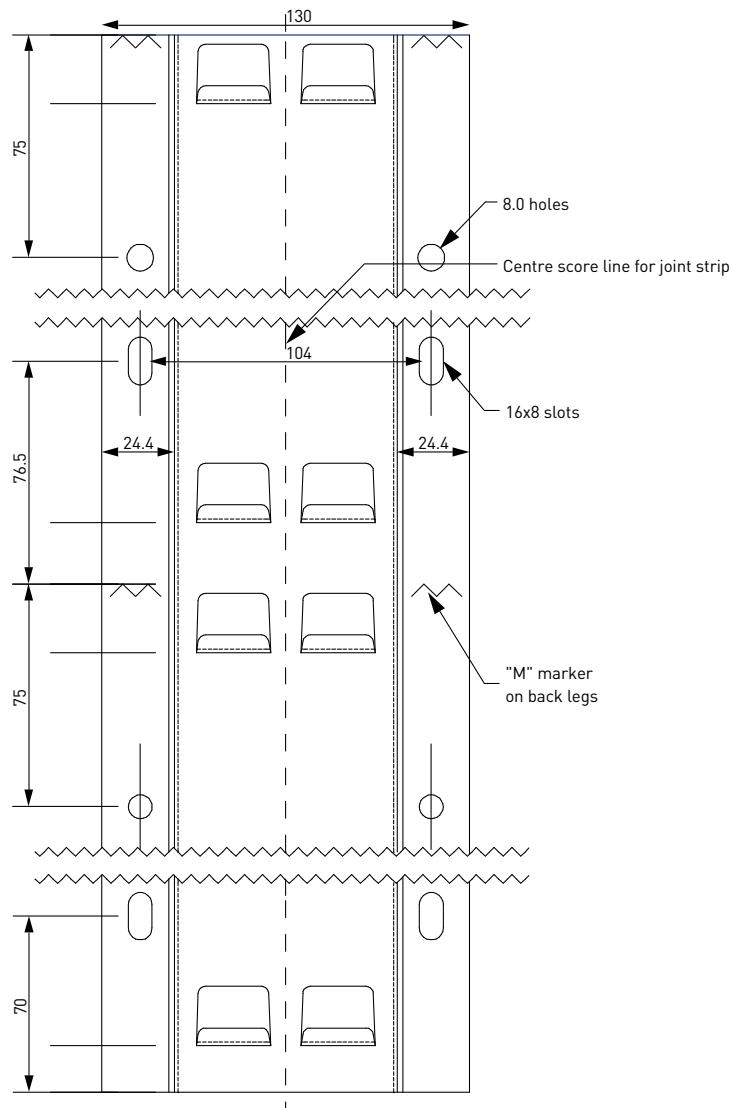

***TN. 01 Suspension Rail, elevation***

**ISSUE F-0122**

© Copyright 2022. Australian New Zealand Patent & Design Registrations. This drawing is indicative only and allowances should be made for material and onsite variations. The component and the assembly details demonstrate a design methodology only. Assembly and documentation drawings should only be undertaken after reference and compliance with the

relevant component's technical data. The diagram is not to scale. For more tailored solutions to suit individual applications, please contact Brickworks Building Products. Brickworks Building Products reserves the rights to add, alter or delete components without prior notice.

# COMPONENTS

## *Terraçade TN Suspension Rail – Plan*

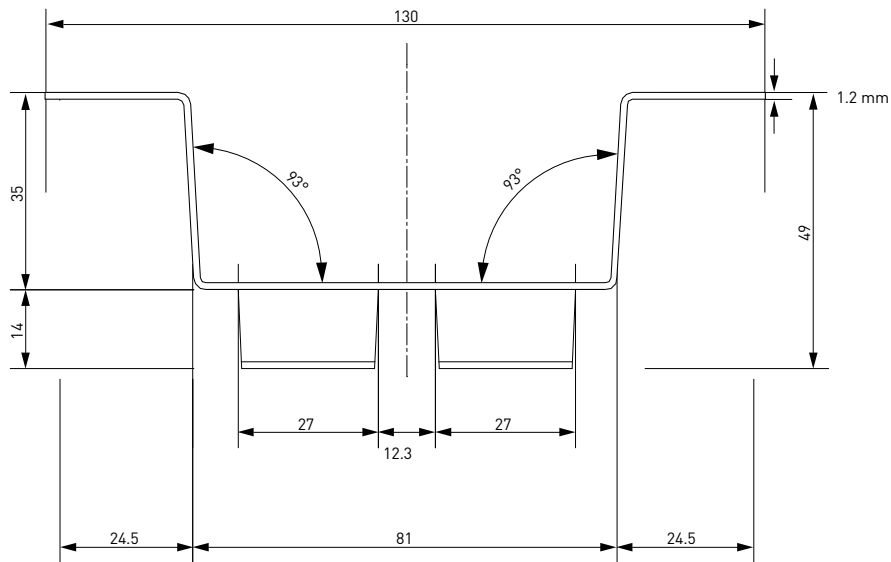

***TN. 01 Suspension Rail, plan***

**ISSUE F-0122**

© Copyright 2022. Australian New Zealand Patent & Design Registrations. This drawing is indicative only and allowances should be made for material and onsite variations. The component and the assembly details demonstrate a design methodology only. Assembly and documentation drawings should only be undertaken after reference and compliance with the

relevant component's technical data. The diagram is not to scale. For more tailored solutions to suit individual applications, please contact Brickworks Building Products. Brickworks Building Products reserves the rights to add, alter or delete components without prior notice.

# COMPONENTS

## *Surround Trim, Corner Trim and Joint Options*

**TN. 02 Aluminium Joint Angle**

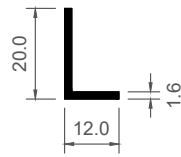

**TN. 03 Aluminium Joint Channel**

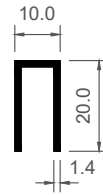

**TN. 05 Aluminium Internal Corner**

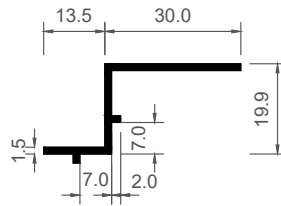

**TN. 07 Modified External Corner**

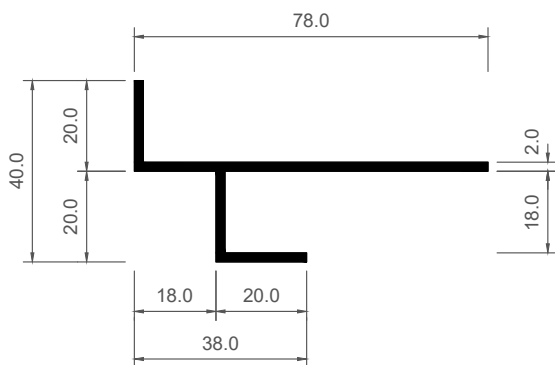

**TN. 09 Standard Surround Trim**

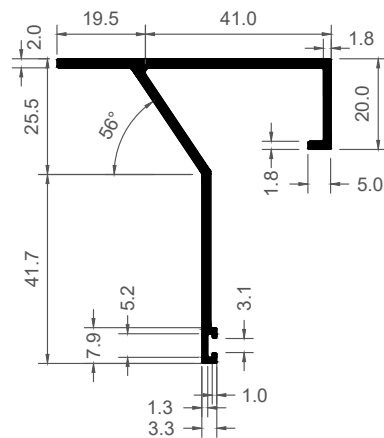

**ISSUE F-0122**

© Copyright 2022. Australian New Zealand Patent & Design Registrations. This drawing is indicative only and allowances should be made for material and onsite variations. The component and the assembly details demonstrate a design methodology only. Assembly and documentation drawings should only be undertaken after reference and compliance with the

relevant component's technical data. The diagram is not to scale. For more tailored solutions to suit individual applications, please contact Brickworks Building Products. Brickworks Building Products reserves the rights to add, alter or delete components without prior notice.

# COMPONENTS

## Other Components

**TN. E2 Fitment Sponge**

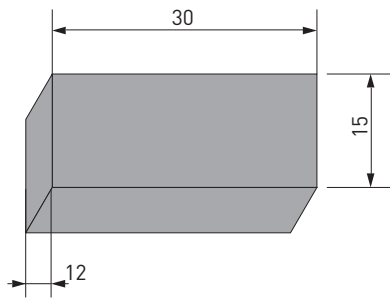

**TN. Set Out Tool**

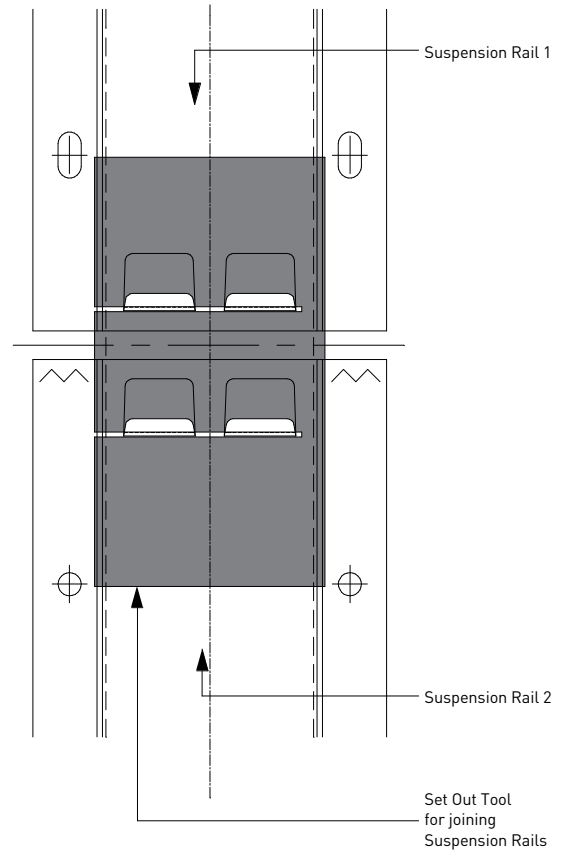

**TN. E4 Anti-Lifting Block**

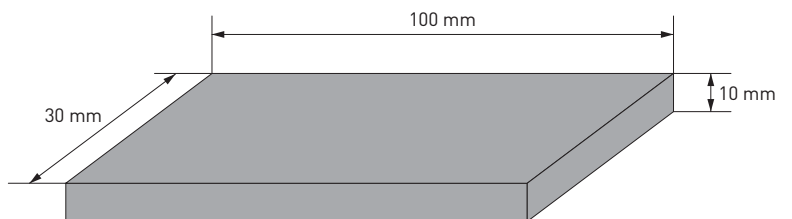

**ISSUE F-0122**

© Copyright 2022. Australian New Zealand Patent & Design Registrations. This drawing is indicative only and allowances should be made for material and onsite variations. The component and the assembly details demonstrate a design methodology only. Assembly and documentation drawings should only be undertaken after reference and compliance with the

relevant component's technical data. The diagram is not to scale. For more tailored solutions to suit individual applications, please contact Brickworks Building Products. Brickworks Building Products reserves the rights to add, alter or delete components without prior notice.



# SYSTEM DESIGN



For the most up to date information on Terraçade products and the latest version of this manual, please refer to our website; [www.terraçade.com.au](http://www.terraçade.com.au)



# SYSTEM DESIGN

Common Details		Page Number
SD-01	Overview	42
SD-02	Side Detail	43
SD-03	Horizontal Detail	44
SD-04	External Corner	45
SD-05	Internal Corner	46
SD-06	Base Detail	47
SD-07	Parapet Detail	48
SD-08	Window Sill	49
SD-09	Window Head	50
SD-10	Window Jamb	51
SD-11	Set-Out Tool	52
SD-12	Rake Detail	53
SD-13	Top Restraint for Earthquake Zones	54
Typical Details for Common Structural Walls		Page Number
D-01	Timber – Horizontal Detail	55
D-02	Timber – Vertical Detail	56
D-03	Timber – Termite Detail (Recessed Slab)	57
D-04	Steel – Horizontal Detail	58
D-05	Steel – Vertical Detail	59
D-06	Concrete – Horizontal Detail	60
D-07	Concrete – Vertical Detail	61
D-08	Masonry – Horizontal Detail	62
D-09	Masonry – Vertical Detail	63

# SYSTEM DESIGN

## Overview – SD 01

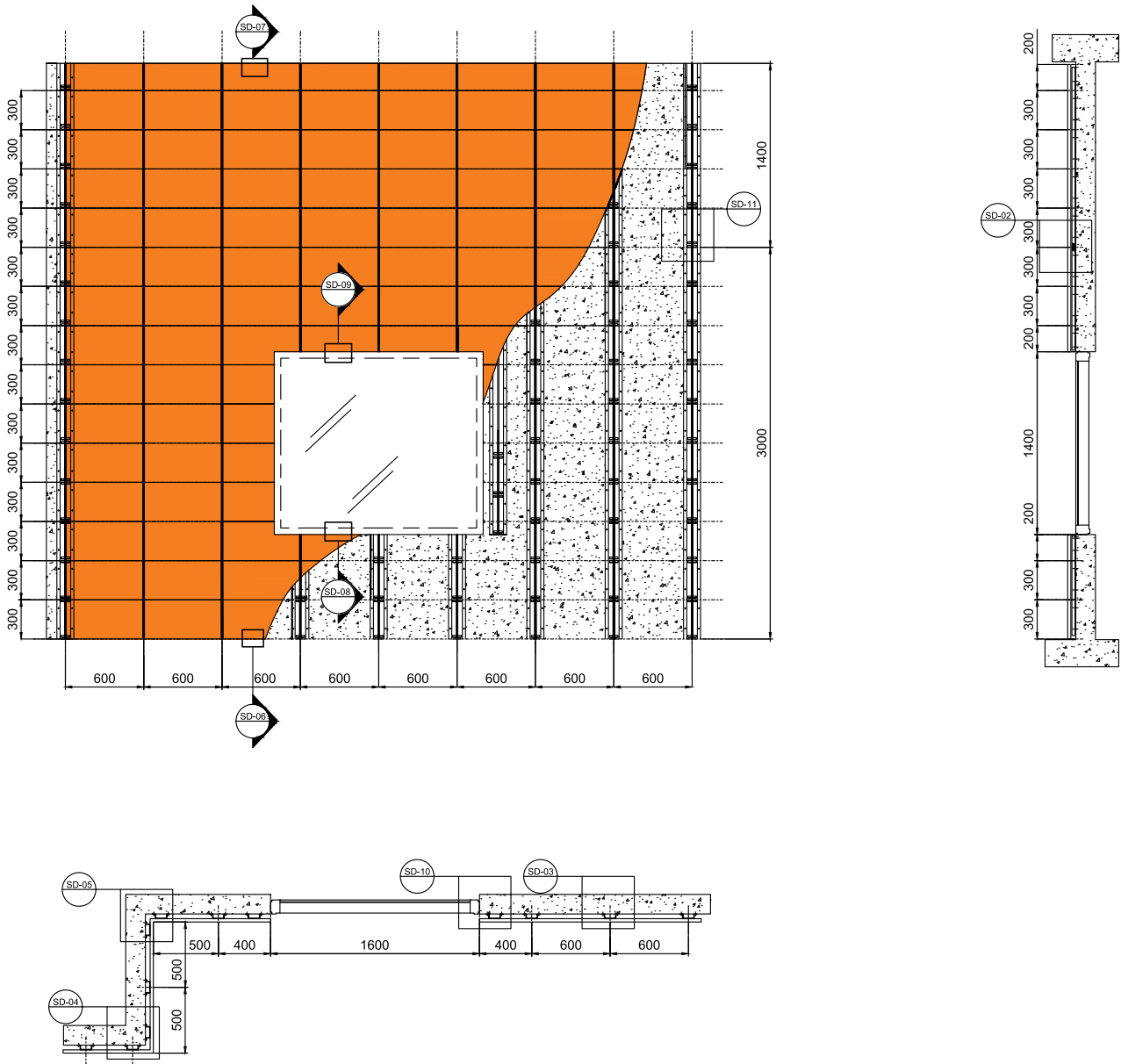

*Terraçade TN set-out with TN.03 Joint Channel*

**ISSUE F-0122**

© Copyright 2022. Australian New Zealand Patent & Design Registrations. This drawing is indicative only and allowances should be made for material and onsite variations. The component and the assembly details demonstrate a design methodology only. Assembly and documentation drawings should only be undertaken after reference and compliance with the

relevant component's technical data. The diagram is not to scale. For more tailored solutions to suit individual applications, please contact Brickworks Building Products. Brickworks Building Products reserves the rights to add, alter or delete components without prior notice.

# SYSTEM DESIGN

## Side Detail – SD 02

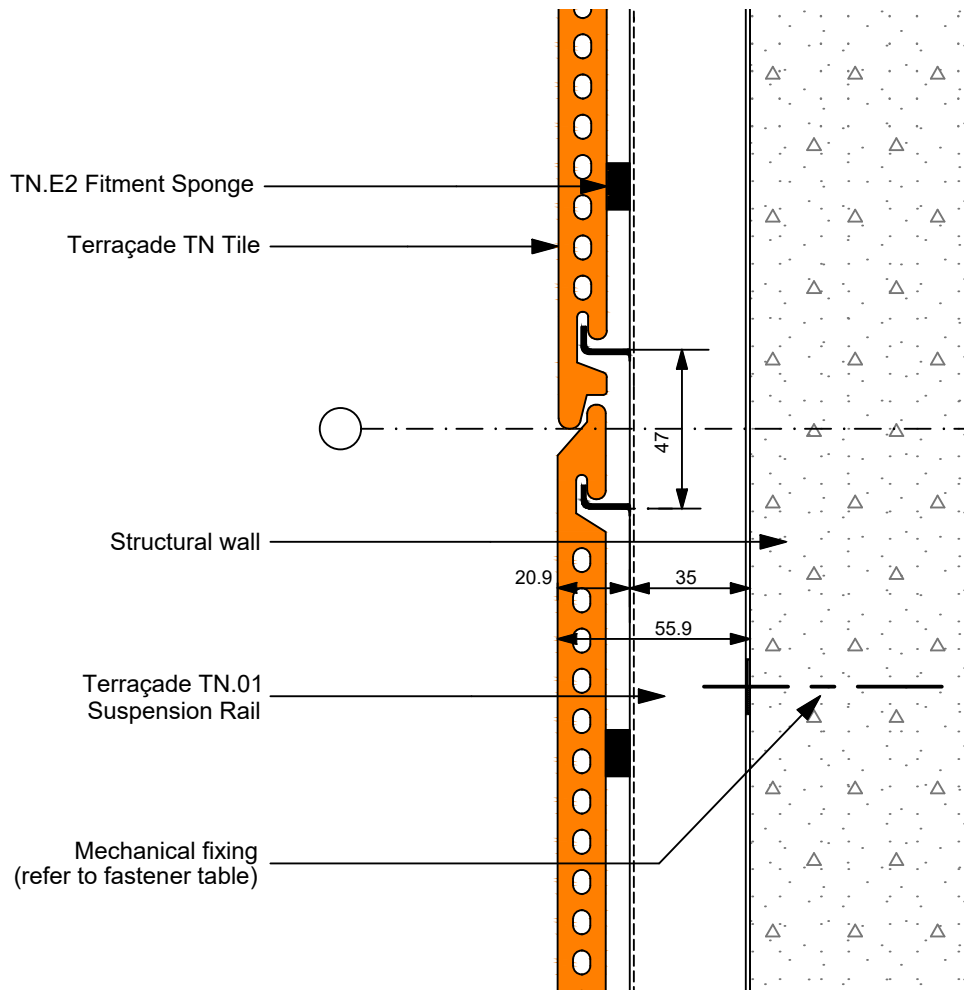

### Handy Tip

- Fitment sponges should be fitted immediately prior to installation of tiles.

#### ISSUE F-0122

© Copyright 2022. Australian New Zealand Patent & Design Registrations. This drawing is indicative only and allowances should be made for material and onsite variations. The component and the assembly details demonstrate a design methodology only. Assembly and documentation drawings should only be undertaken after reference and compliance with the

relevant component's technical data. The diagram is not to scale. For more tailored solutions to suit individual applications, please contact Brickworks Building Products. Brickworks Building Products reserves the rights to add, alter or delete components without prior notice.

# SYSTEM DESIGN

## *Horizontal Detail – SD 03*

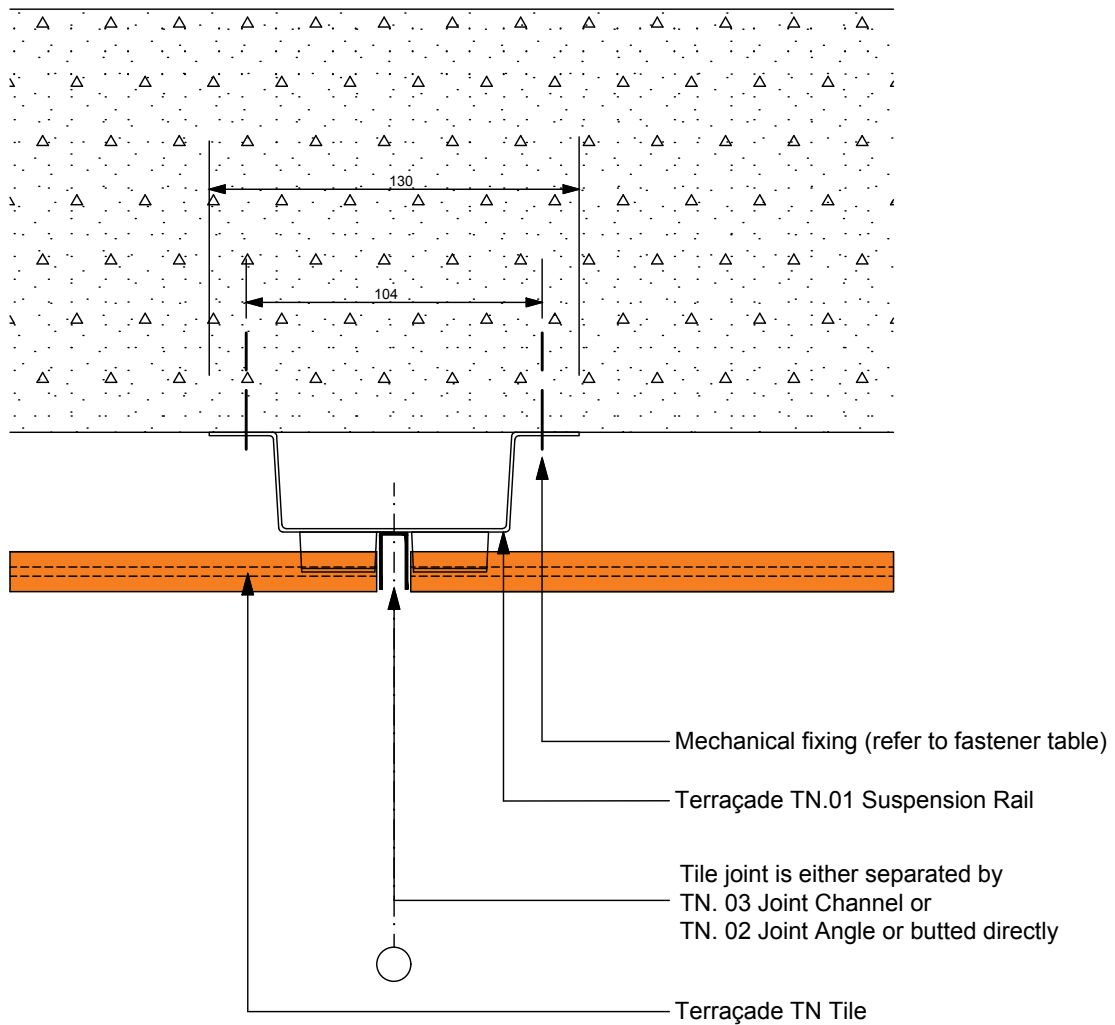

**ISSUE F-0122**

© Copyright 2022. Australian New Zealand Patent & Design Registrations. This drawing is indicative only and allowances should be made for material and onsite variations. The component and the assembly details demonstrate a design methodology only. Assembly and documentation drawings should only be undertaken after reference and compliance with the

relevant component's technical data. The diagram is not to scale. For more tailored solutions to suit individual applications, please contact Brickworks Building Products. Brickworks Building Products reserves the rights to add, alter or delete components without prior notice.

# SYSTEM DESIGN

## External Corner – SD 04

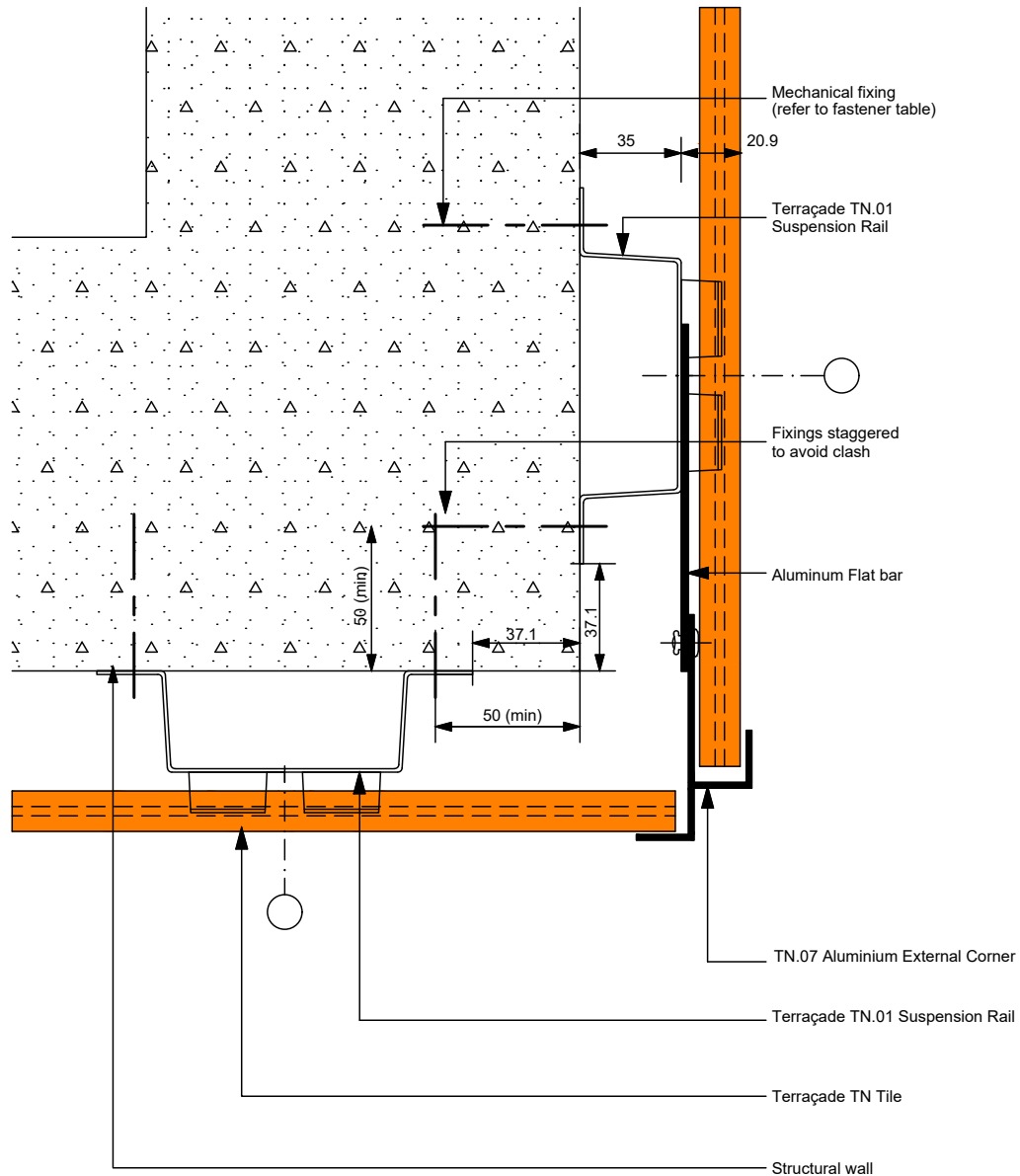

**ISSUE F-0122**

© Copyright 2022. Australian New Zealand Patent & Design Registrations. This drawing is indicative only and allowances should be made for material and onsite variations. The component and the assembly details demonstrate a design methodology only. Assembly and documentation drawings should only be undertaken after reference and compliance with the

relevant component's technical data. The diagram is not to scale. For more tailored solutions to suit individual applications, please contact Brickworks Building Products. Brickworks Building Products reserves the rights to add, alter or delete components without prior notice.

# SYSTEM DESIGN

## *Internal Corner – SD 05*

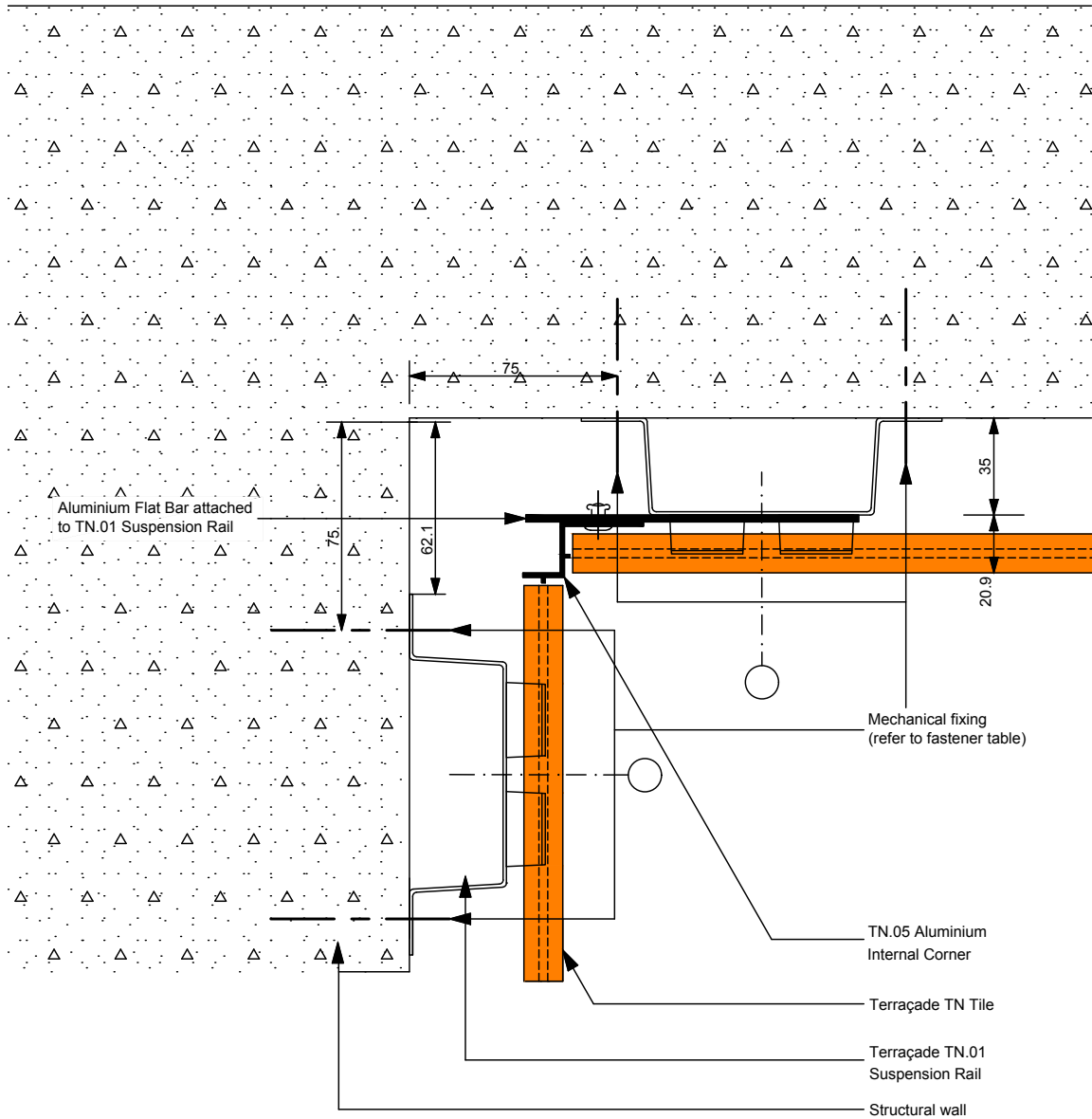

**ISSUE F-0122**

© Copyright 2022. Australian New Zealand Patent & Design Registrations. This drawing is indicative only and allowances should be made for material and onsite variations. The component and the assembly details demonstrate a design methodology only. Assembly and documentation drawings should only be undertaken after reference and compliance with the

relevant component's technical data. The diagram is not to scale. For more tailored solutions to suit individual applications, please contact Brickworks Building Products. Brickworks Building Products reserves the rights to add, alter or delete components without prior notice.

# SYSTEM DESIGN

## Base Detail – SD 06

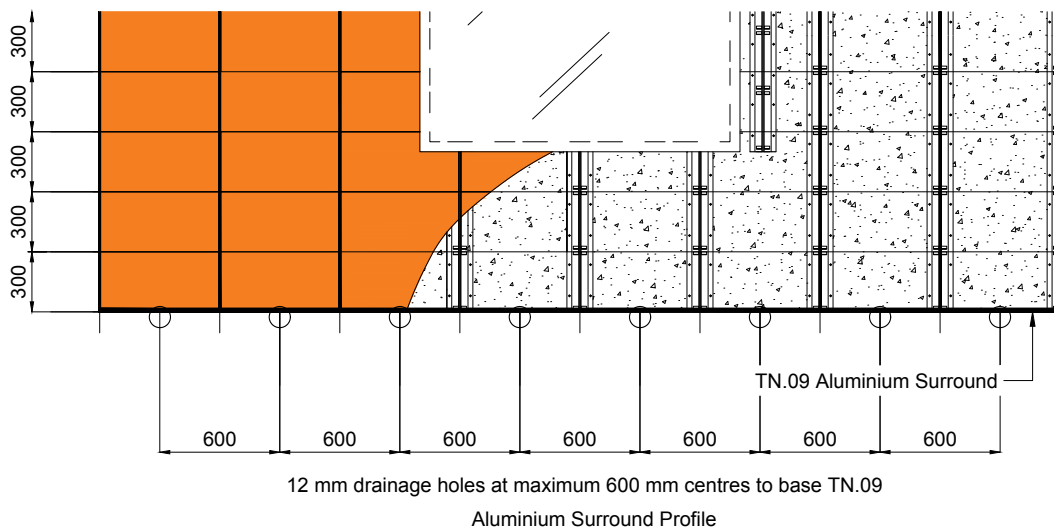
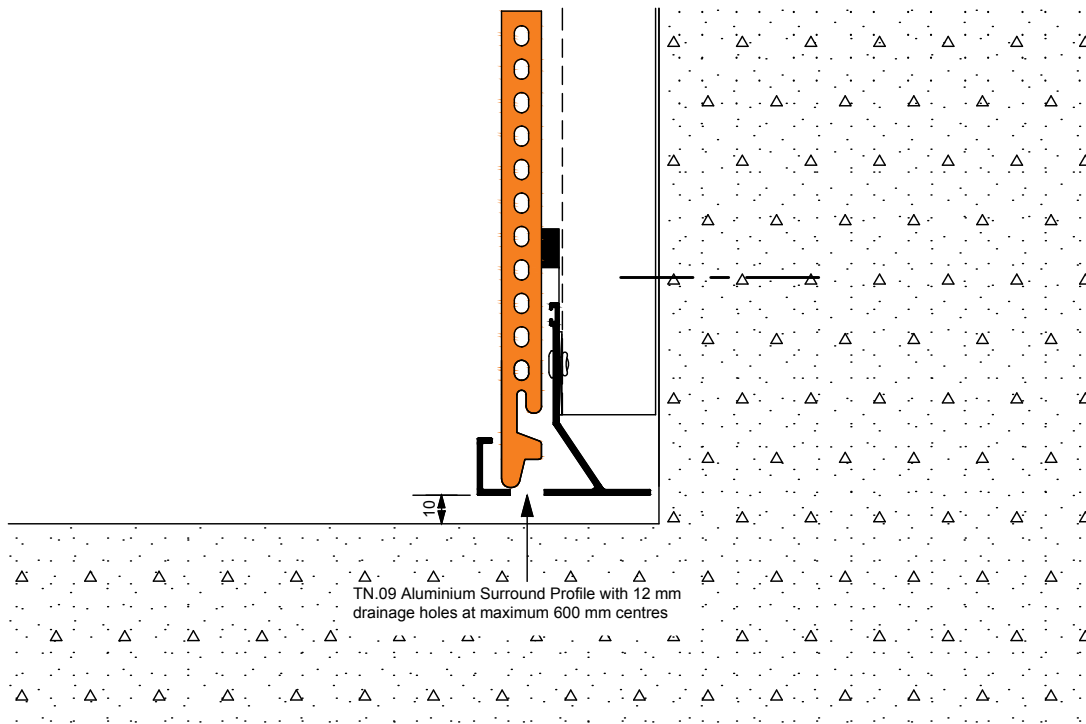

### ISSUE F-0122

© Copyright 2022. Australian New Zealand Patent & Design Registrations. This drawing is indicative only and allowances should be made for material and onsite variations. The component and the assembly details demonstrate a design methodology only. Assembly and documentation drawings should only be undertaken after reference and compliance with the

relevant component's technical data. The diagram is not to scale. For more tailored solutions to suit individual applications, please contact Brickworks Building Products. Brickworks Building Products reserves the rights to add, alter or delete components without prior notice.

# SYSTEM DESIGN

## *Parapet Detail – SD 07*

**Whole Tile**

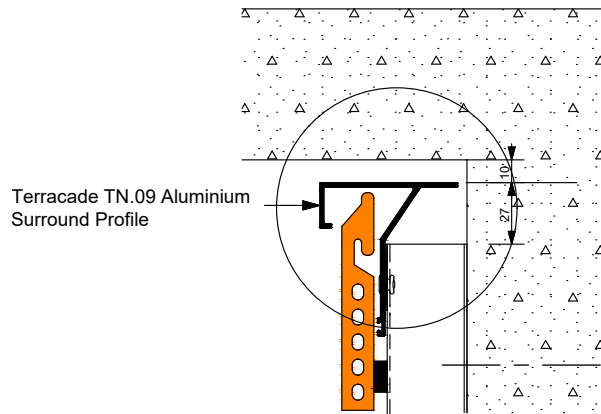

**Cut Tile**

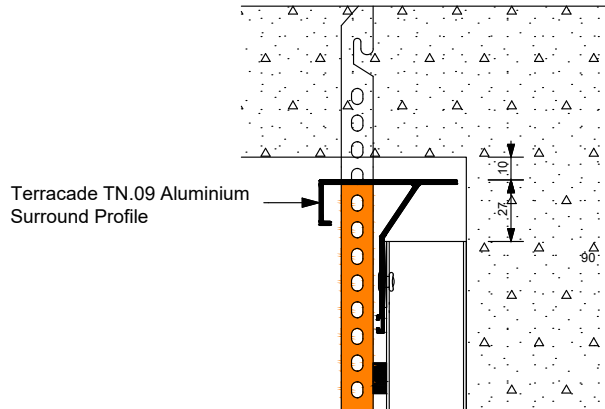

### Handy Tip

- If fixing to structural wall and the suspension rail, allow a 10mm gap.

**ISSUE F-0122**

© Copyright 2022. Australian New Zealand Patent & Design Registrations. This drawing is indicative only and allowances should be made for material and onsite variations. The component and the assembly details demonstrate a design methodology only. Assembly and documentation drawings should only be undertaken after reference and compliance with the

relevant component's technical data. The diagram is not to scale. For more tailored solutions to suit individual applications, please contact Brickworks Building Products. Brickworks Building Products reserves the rights to add, alter or delete components without prior notice.



# SYSTEM DESIGN

## Window Sill – SD 08

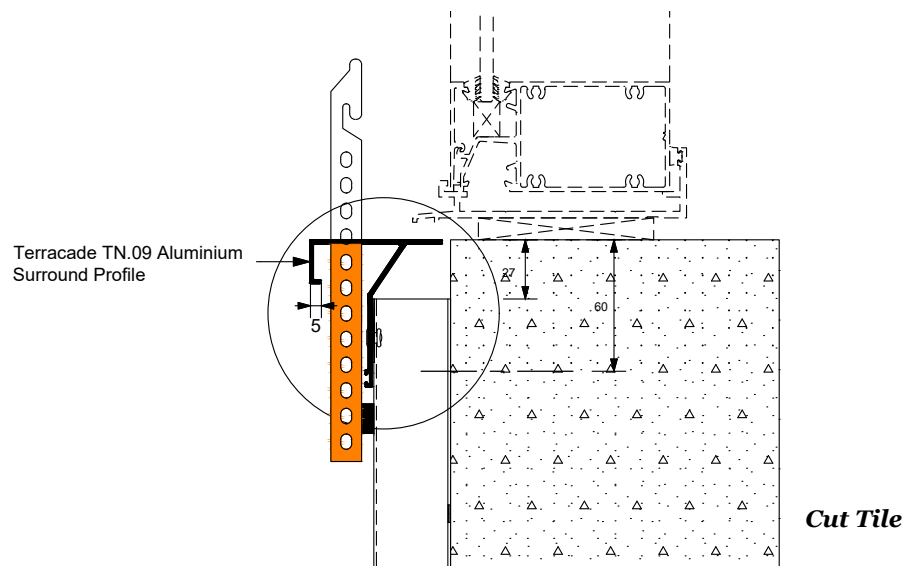
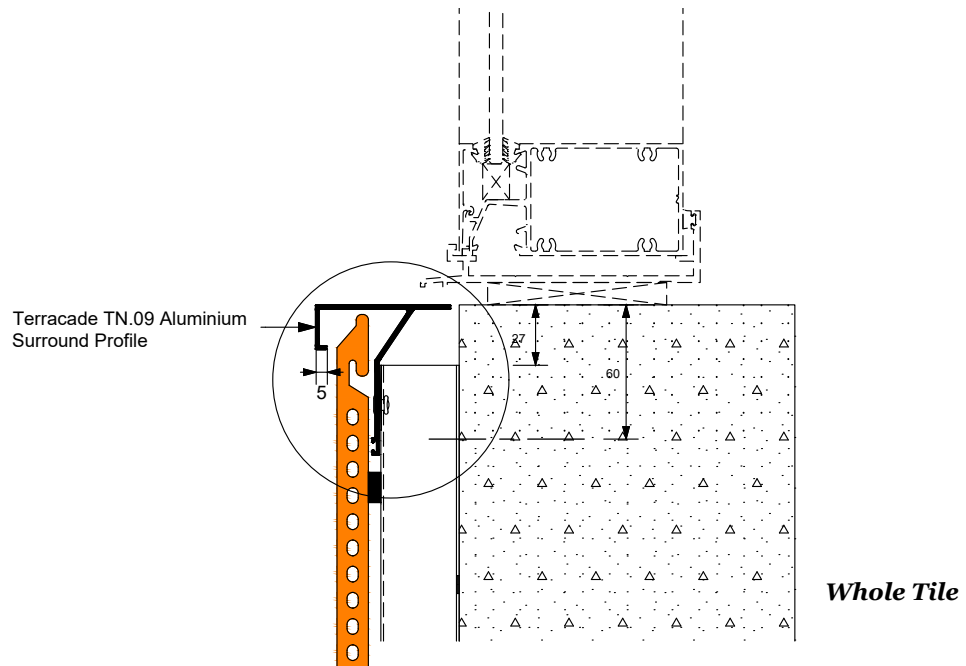

### ISSUE F-0122

© Copyright 2022. Australian New Zealand Patent & Design Registrations. This drawing is indicative only and allowances should be made for material and onsite variations. The component and the assembly details demonstrate a design methodology only. Assembly and documentation drawings should only be undertaken after reference and compliance with the

relevant component's technical data. The diagram is not to scale. For more tailored solutions to suit individual applications, please contact Brickworks Building Products. Brickworks Building Products reserves the rights to add, alter or delete components without prior notice.

# SYSTEM DESIGN

## Window Head – SD 09

### Whole Tile

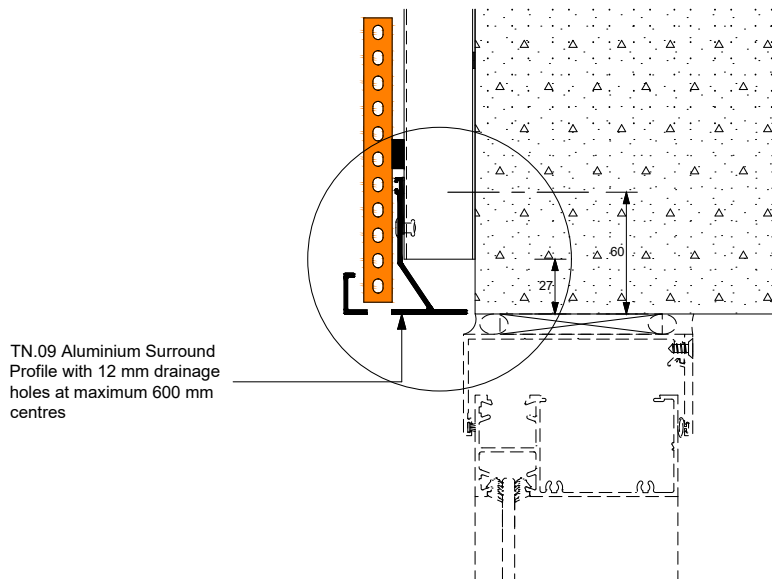
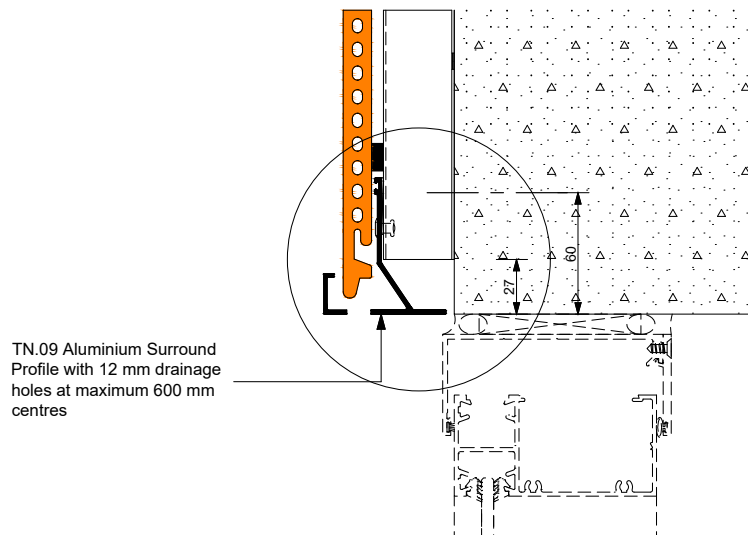

### Cut Tile

**ISSUE F-0122**

© Copyright 2022. Australian New Zealand Patent & Design Registrations. This drawing is indicative only and allowances should be made for material and onsite variations. The component and the assembly details demonstrate a design methodology only. Assembly and documentation drawings should only be undertaken after reference and compliance with the

relevant component's technical data. The diagram is not to scale. For more tailored solutions to suit individual applications, please contact Brickworks Building Products. Brickworks Building Products reserves the rights to add, alter or delete components without prior notice.

# SYSTEM DESIGN

## *Window Jamb – SD 10*

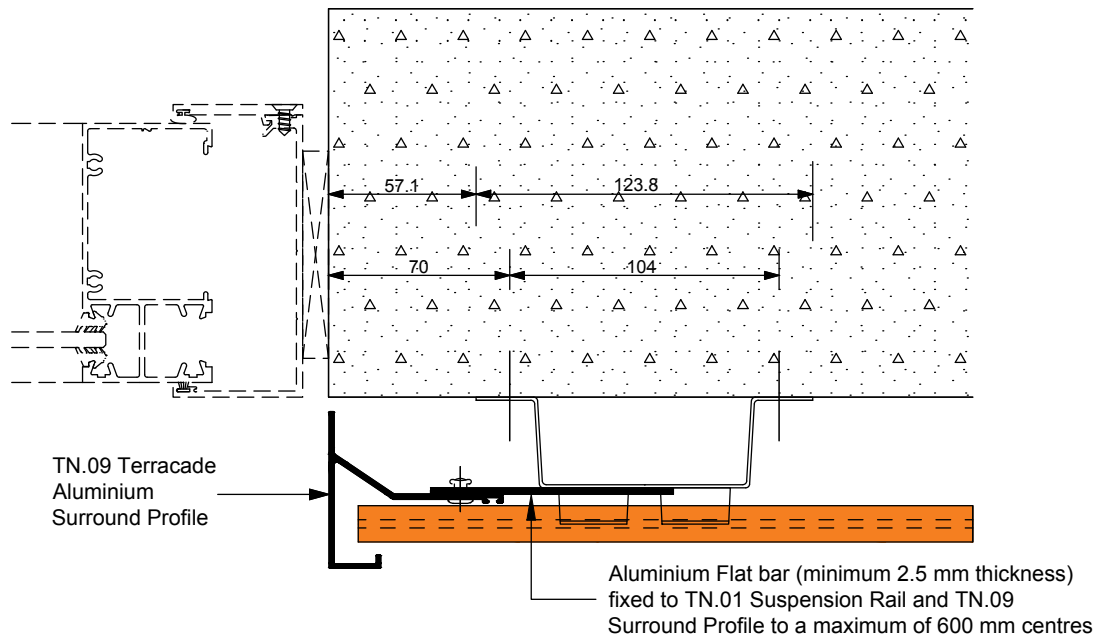

### ISSUE F-0122

© Copyright 2022. Australian New Zealand Patent & Design Registrations. This drawing is indicative only and allowances should be made for material and onsite variations. The component and the assembly details demonstrate a design methodology only. Assembly and documentation drawings should only be undertaken after reference and compliance with the

relevant component's technical data. The diagram is not to scale. For more tailored solutions to suit individual applications, please contact Brickworks Building Products. Brickworks Building Products reserves the rights to add, alter or delete components without prior notice.

## SYSTEM DESIGN

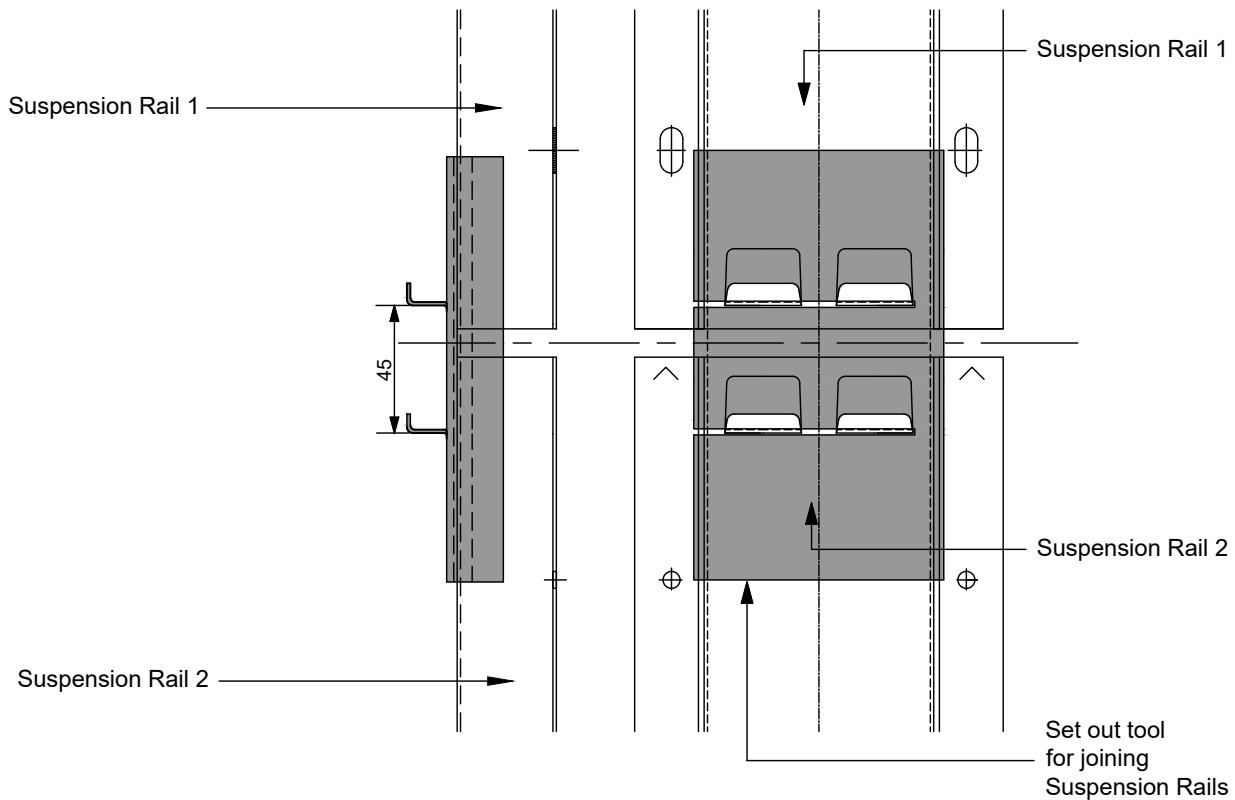
*Set-Out Tool – SD 11*

## Handy Tip

- The Set Out Tool maintains the vertical continuity of the system when joining rails on above the other. The tool is slotted onto the rails and then removed when both rails are fixed.

## ISSUE F-0122

© Copyright 2022. Australian New Zealand Patent & Design Registrations. This drawing is indicative only and allowances should be made for material and onsite variations. The component and the assembly details demonstrate a design methodology only. Assembly and documentation drawings should only be undertaken after reference and compliance with the

relevant component's technical data. The diagram is not to scale. For more tailored solutions to suit individual applications, please contact Brickworks Building Products. Brickworks Building Products reserves the rights to add, alter or delete components without prior notice.

# SYSTEM DESIGN

## *Rake Detail – SD 12*

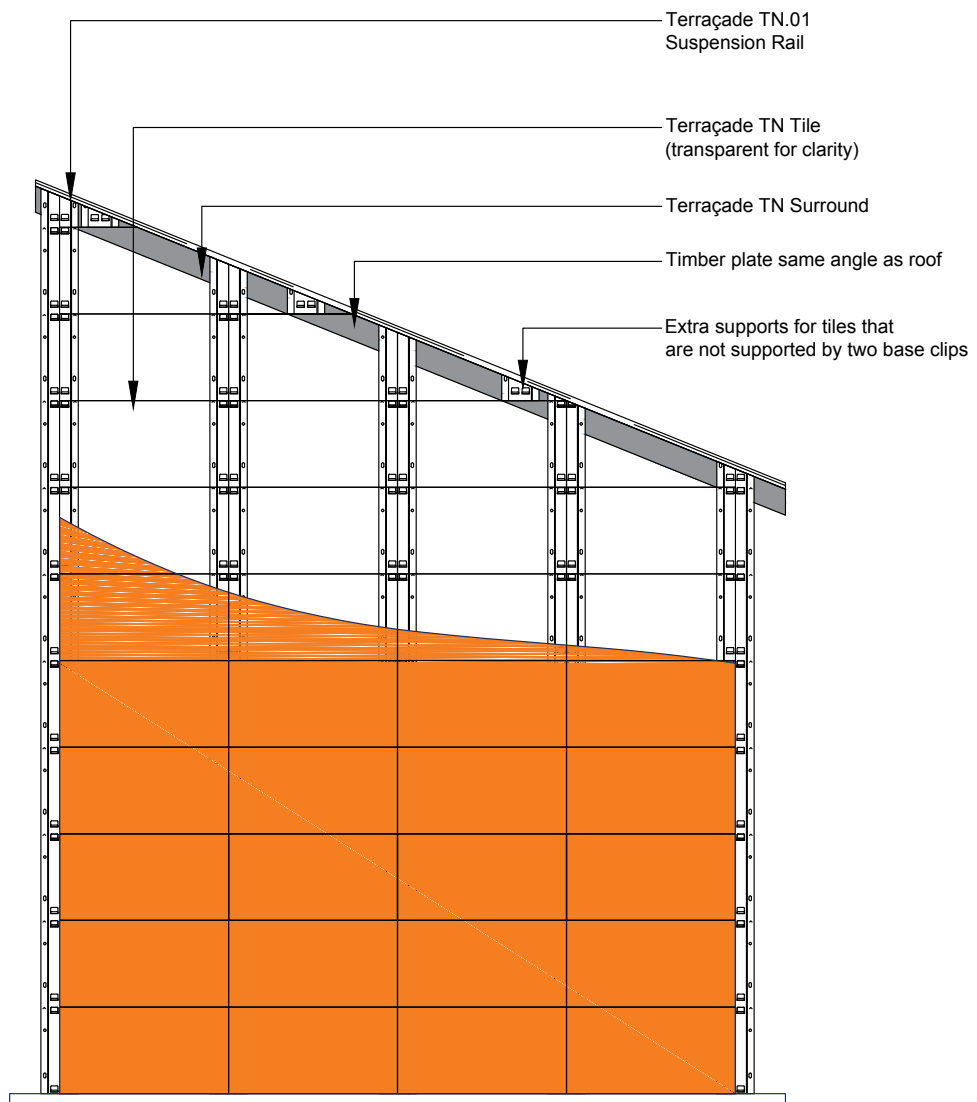

### ISSUE F-0122

© Copyright 2022. Australian New Zealand Patent & Design Registrations. This drawing is indicative only and allowances should be made for material and onsite variations. The component and the assembly details demonstrate a design methodology only. Assembly and documentation drawings should only be undertaken after reference and compliance with the

relevant component's technical data. The diagram is not to scale. For more tailored solutions to suit individual applications, please contact Brickworks Building Products. Brickworks Building Products reserves the rights to add, alter or delete components without prior notice.

# SYSTEM DESIGN

## *Top Restraint for Earthquake Zones – SD 13*

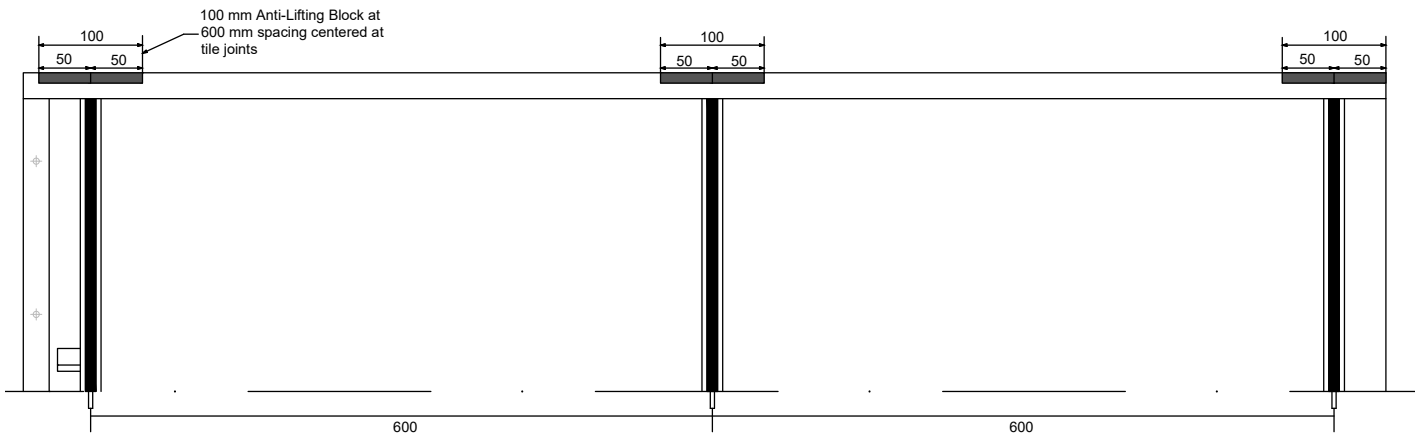
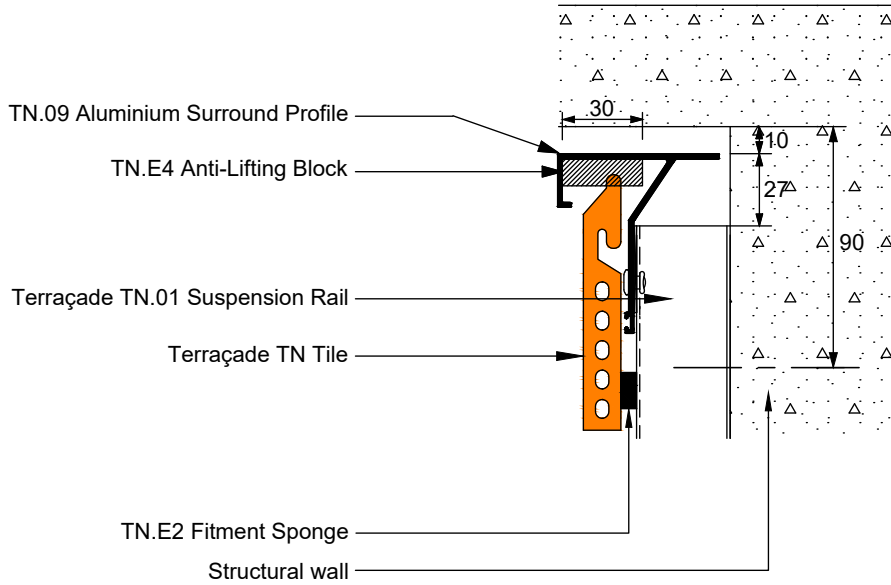

**ISSUE F-0122**

© Copyright 2022. Australian New Zealand Patent & Design Registrations. This drawing is indicative only and allowances should be made for material and onsite variations. The component and the assembly details demonstrate a design methodology only. Assembly and documentation drawings should only be undertaken after reference and compliance with the

relevant component's technical data. The diagram is not to scale. For more tailored solutions to suit individual applications, please contact Brickworks Building Products. Brickworks Building Products reserves the rights to add, alter or delete components without prior notice.

# SYSTEM DESIGN

## *Horizontal Detail – D-01 Timber*

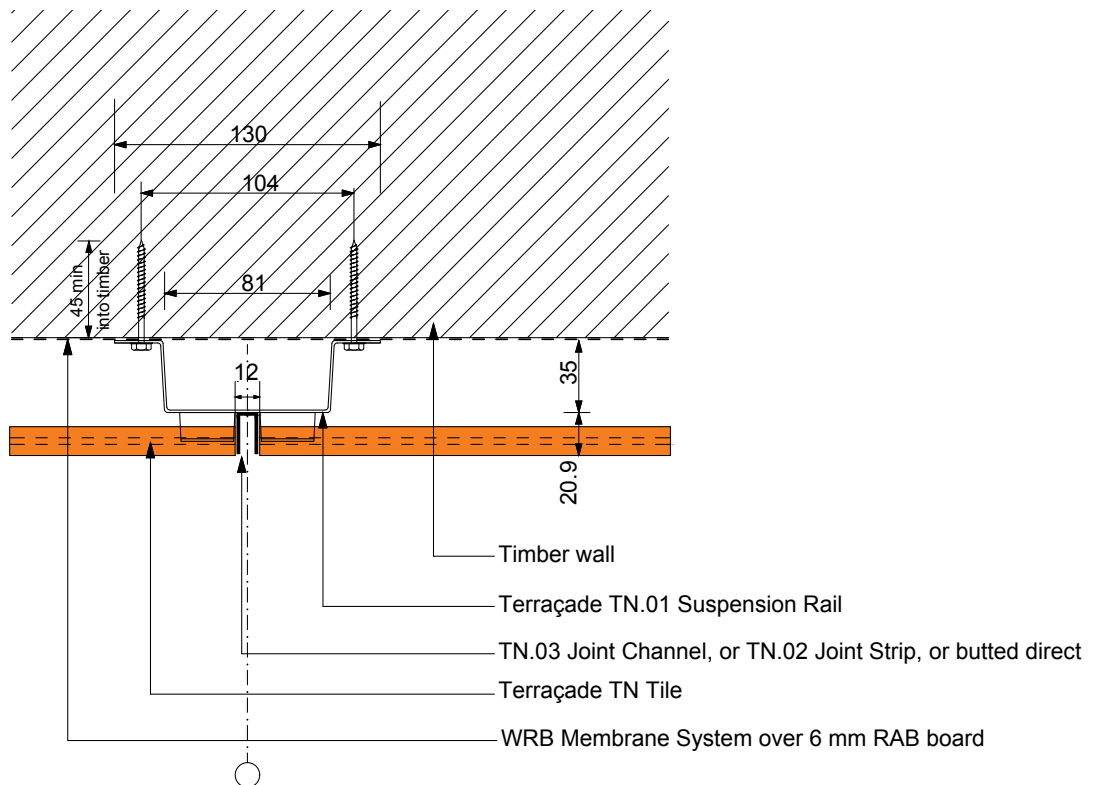

### Handy Tip

- Spray or brush the central section of the coastal version suspension rail face (between the hanging tabs) matt black to reduce reflection through any gaps.

### ISSUE F-0122

© Copyright 2022. Australian New Zealand Patent & Design Registrations. This drawing is indicative only and allowances should be made for material and onsite variations. The component and the assembly details demonstrate a design methodology only. Assembly and documentation drawings should only be undertaken after reference and compliance with the

relevant component's technical data. The diagram is not to scale. For more tailored solutions to suit individual applications, please contact Brickworks Building Products. Brickworks Building Products reserves the rights to add, alter or delete components without prior notice.

# SYSTEM DESIGN

## *Vertical Detail – D-02 Timber*

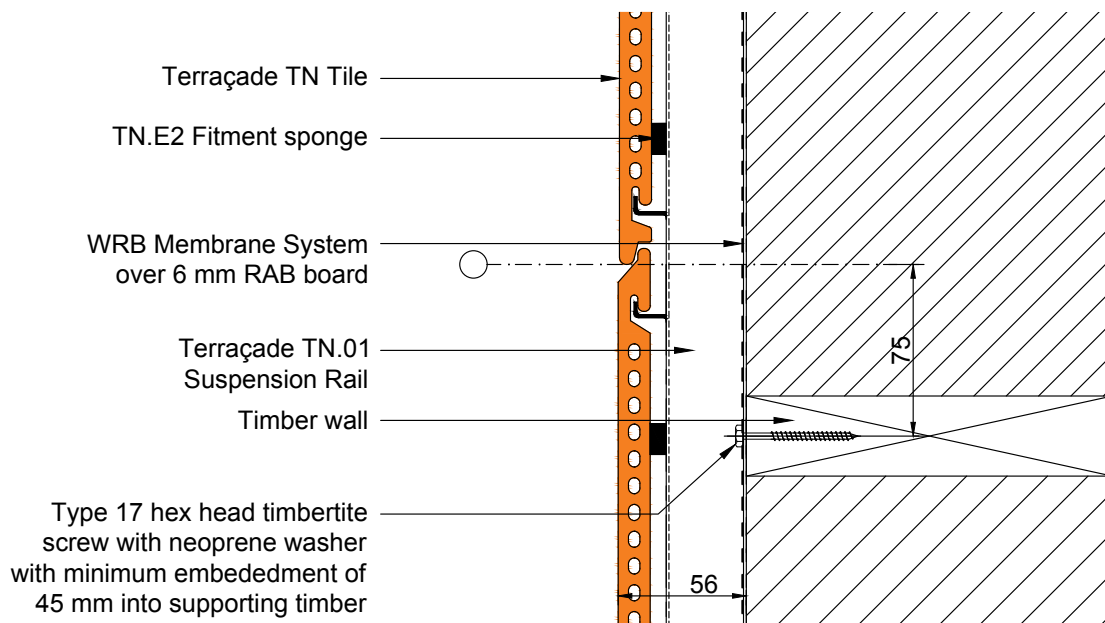

**ISSUE F-0122**

© Copyright 2022. Australian New Zealand Patent & Design Registrations. This drawing is indicative only and allowances should be made for material and onsite variations. The component and the assembly details demonstrate a design methodology only. Assembly and documentation drawings should only be undertaken after reference and compliance with the

relevant component's technical data. The diagram is not to scale. For more tailored solutions to suit individual applications, please contact Brickworks Building Products. Brickworks Building Products reserves the rights to add, alter or delete components without prior notice.



# SYSTEM DESIGN

## *Recessed Slab – D-03 Termite Detail*

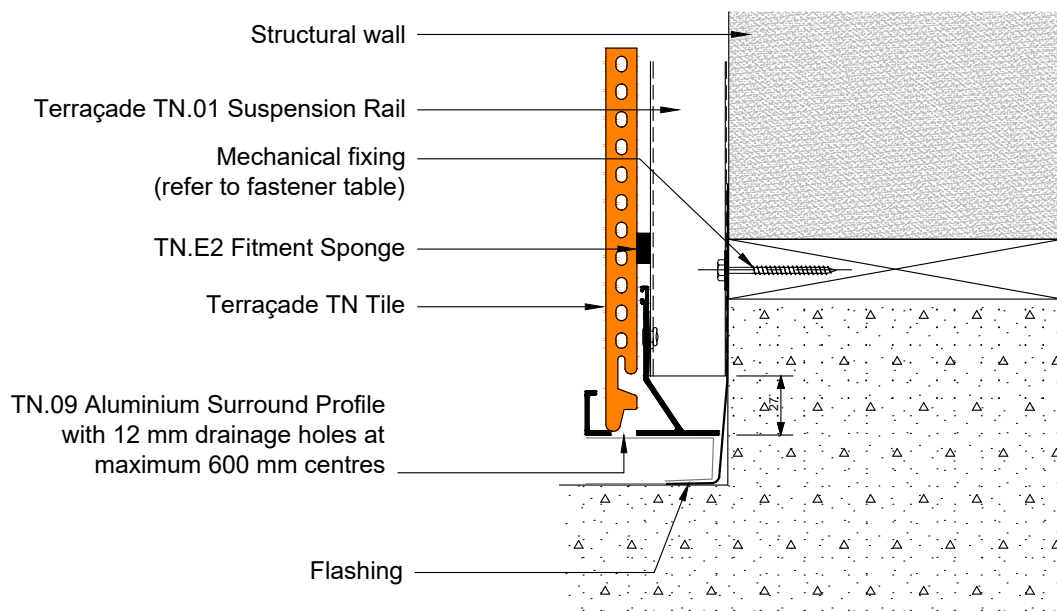

**ISSUE F-0122**

© Copyright 2022. Australian New Zealand Patent & Design Registrations. This drawing is indicative only and allowances should be made for material and onsite variations. The component and the assembly details demonstrate a design methodology only. Assembly and documentation drawings should only be undertaken after reference and compliance with the

relevant component's technical data. The diagram is not to scale. For more tailored solutions to suit individual applications, please contact Brickworks Building Products. Brickworks Building Products reserves the rights to add, alter or delete components without prior notice.

## SYSTEM DESIGN

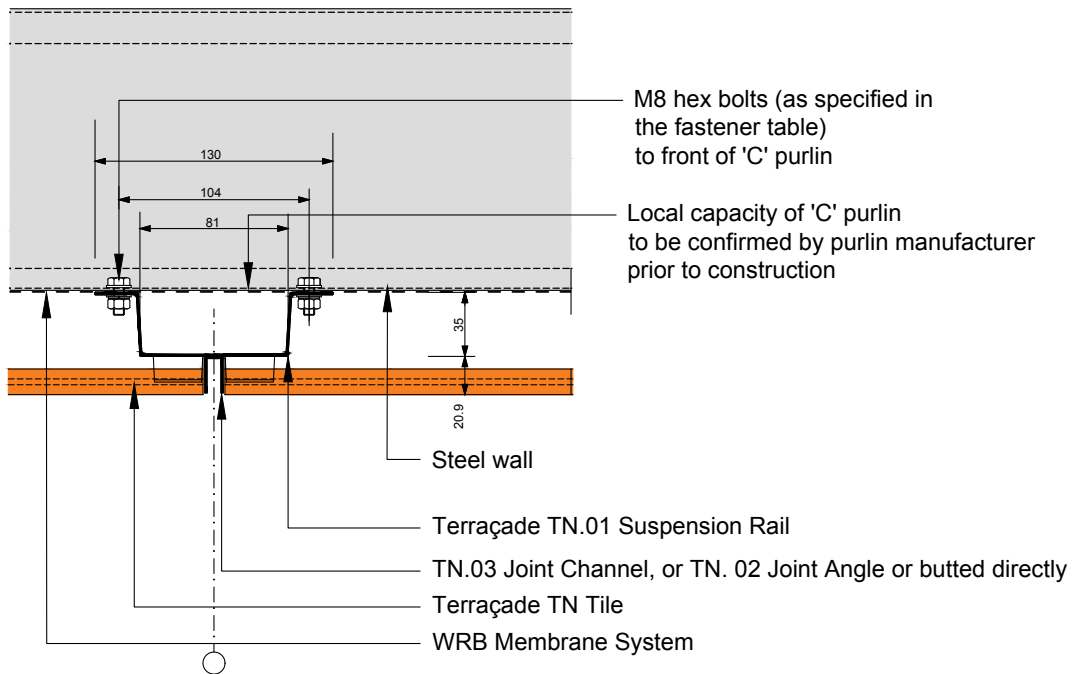
*Horizontal Detail – D-04 Steel*

## Handy Tip

- Spray or brush the central section of the coastal version suspension rail face (between the hanging tabs) matt black to reduce reflection through any gaps.

## ISSUE F-0122

© Copyright 2022. Australian New Zealand Patent & Design Registrations. This drawing is indicative only and allowances should be made for material and onsite variations. The component and the assembly details demonstrate a design methodology only. Assembly and documentation drawings should only be undertaken after reference and compliance with the

relevant component's technical data. The diagram is not to scale. For more tailored solutions to suit individual applications, please contact Brickworks Building Products. Brickworks Building Products reserves the rights to add, alter or delete components without prior notice.

# SYSTEM DESIGN

## *Vertical Detail – D-05 Steel*

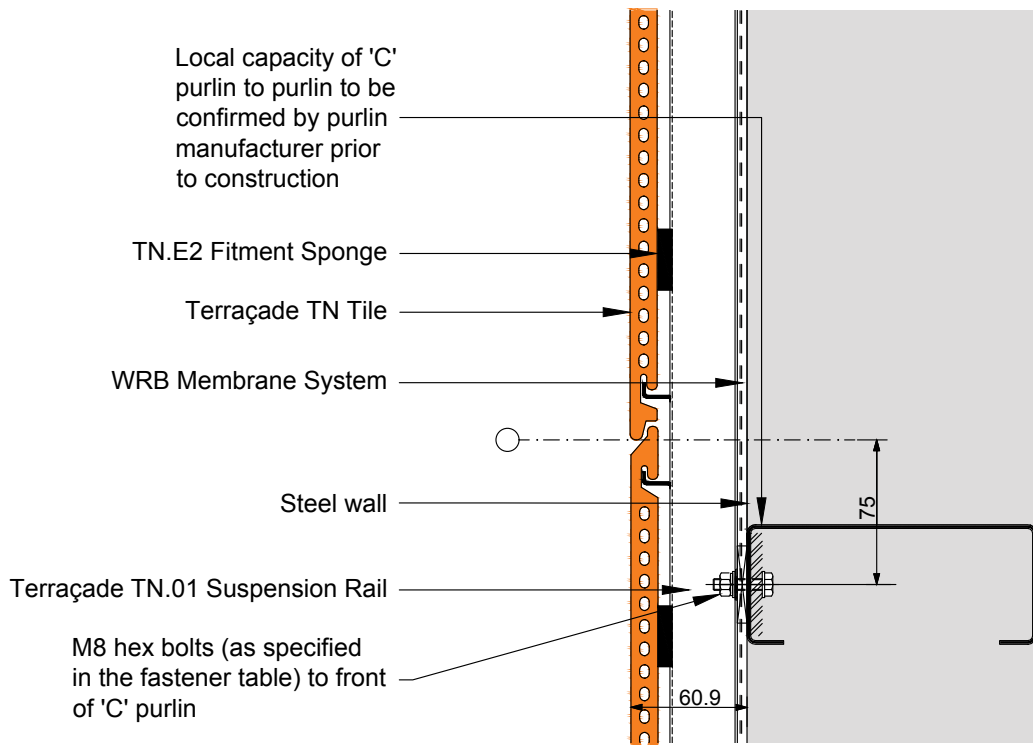

**ISSUE F-0122**

© Copyright 2022. Australian New Zealand Patent & Design Registrations. This drawing is indicative only and allowances should be made for material and onsite variations. The component and the assembly details demonstrate a design methodology only. Assembly and documentation drawings should only be undertaken after reference and compliance with the

relevant component's technical data. The diagram is not to scale. For more tailored solutions to suit individual applications, please contact Brickworks Building Products. Brickworks Building Products reserves the rights to add, alter or delete components without prior notice.

## SYSTEM DESIGN

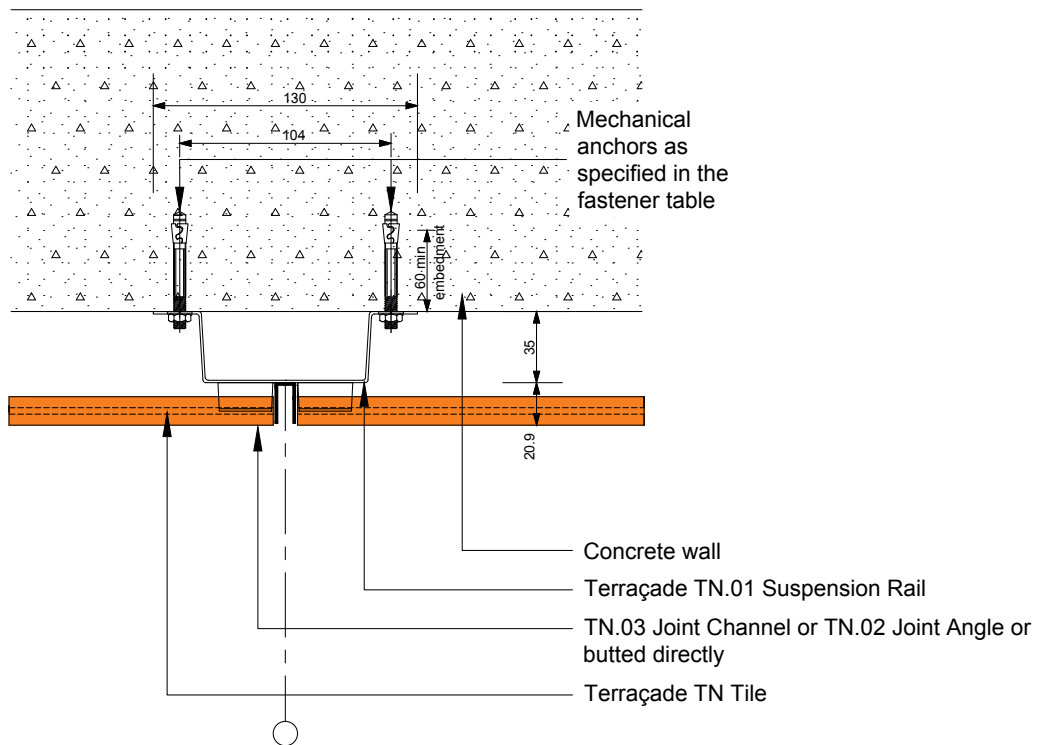
*Horizontal Detail – D-06 Concrete*

## Handy Tip

- Spray or brush the central section of the coastal version suspension rail face (between the hanging tabs) matt black to reduce reflection through any gaps.

## ISSUE F-0122

© Copyright 2022. Australian New Zealand Patent & Design Registrations. This drawing is indicative only and allowances should be made for material and onsite variations. The component and the assembly details demonstrate a design methodology only. Assembly and documentation drawings should only be undertaken after reference and compliance with the

relevant component's technical data. The diagram is not to scale. For more tailored solutions to suit individual applications, please contact Brickworks Building Products. Brickworks Building Products reserves the rights to add, alter or delete components without prior notice.

# SYSTEM DESIGN

## *Vertical Detail – D-07 Concrete*

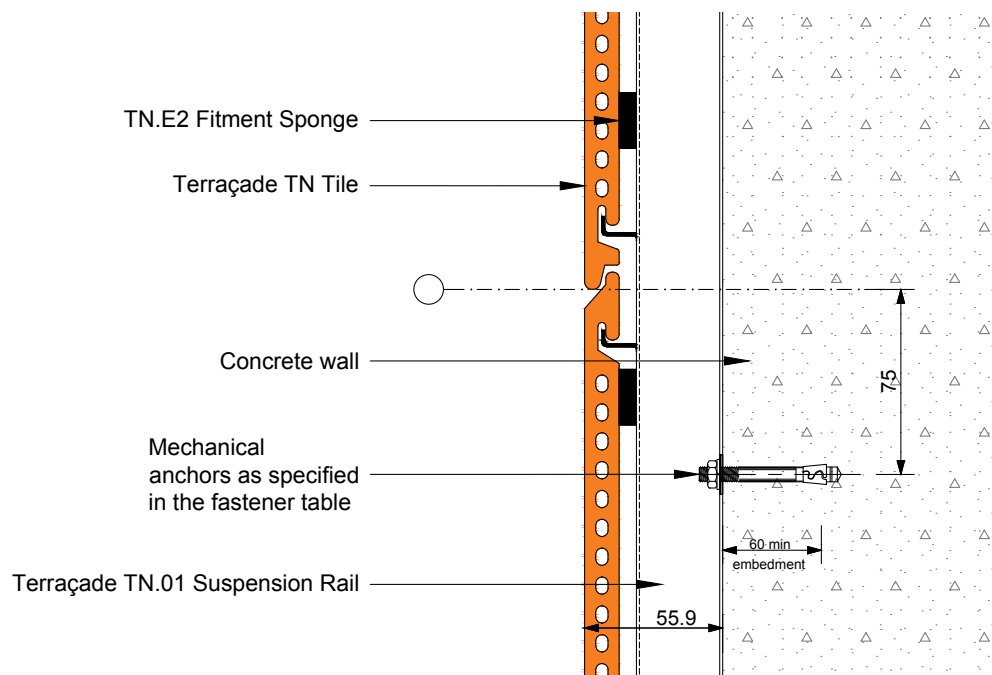

### ISSUE F-0122

© Copyright 2022. Australian New Zealand Patent & Design Registrations. This drawing is indicative only and allowances should be made for material and onsite variations. The component and the assembly details demonstrate a design methodology only. Assembly and documentation drawings should only be undertaken after reference and compliance with the

relevant component's technical data. The diagram is not to scale. For more tailored solutions to suit individual applications, please contact Brickworks Building Products. Brickworks Building Products reserves the rights to add, alter or delete components without prior notice.

# SYSTEM DESIGN

## *Horizontal Detail – D-o8 Masonry*

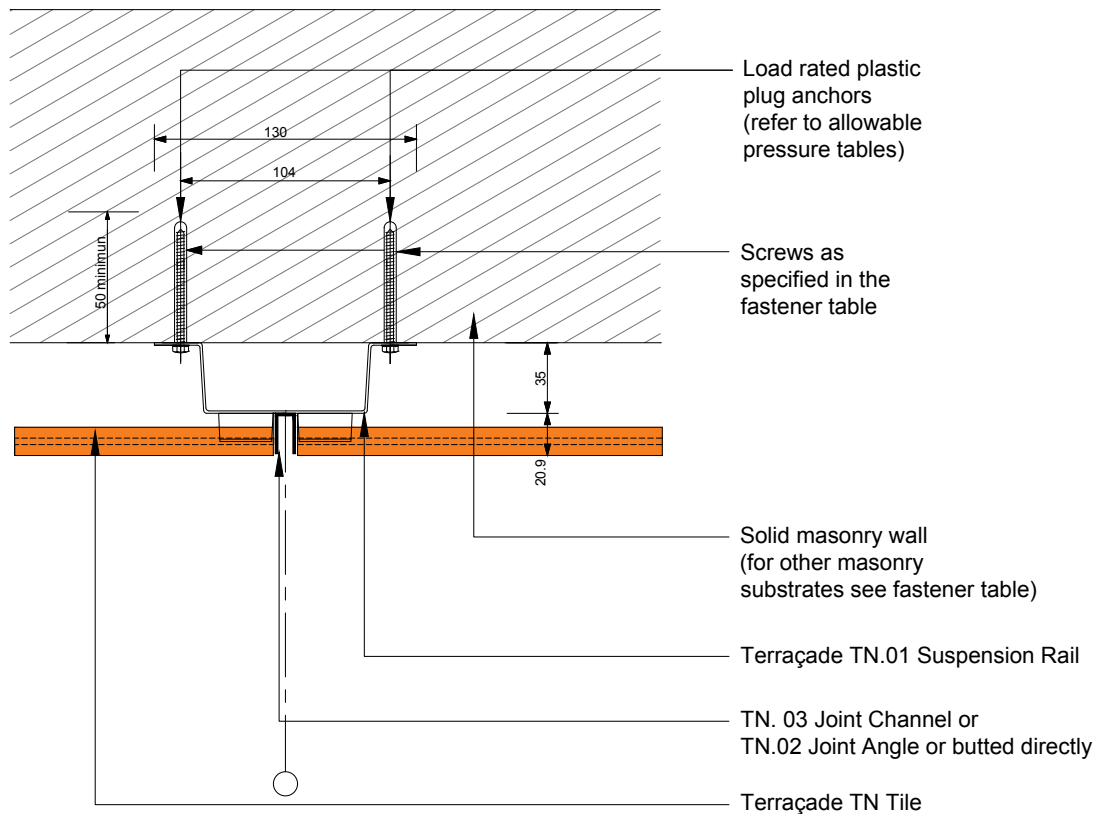

### Handy Tip

- Spray or brush the central section of the coastal version suspension rail face (between the hanging tabs) matt black to reduce reflection through any gaps.

### ISSUE F-0122

© Copyright 2022. Australian New Zealand Patent & Design Registrations. This drawing is indicative only and allowances should be made for material and onsite variations. The component and the assembly details demonstrate a design methodology only. Assembly and documentation drawings should only be undertaken after reference and compliance with the

relevant component's technical data. The diagram is not to scale. For more tailored solutions to suit individual applications, please contact Brickworks Building Products. Brickworks Building Products reserves the rights to add, alter or delete components without prior notice.

# SYSTEM DESIGN

## *Vertical Detail – D-09 Masonry*

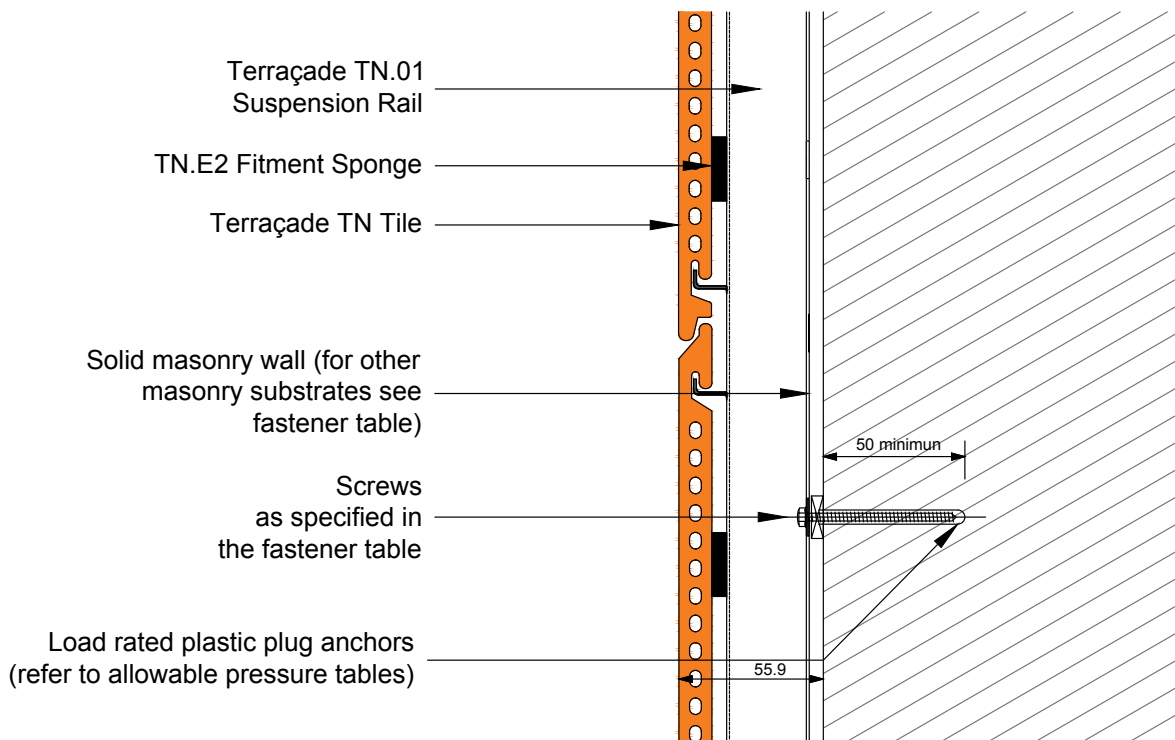

### ISSUE F-0122

© Copyright 2022. Australian New Zealand Patent & Design Registrations. This drawing is indicative only and allowances should be made for material and onsite variations. The component and the assembly details demonstrate a design methodology only. Assembly and documentation drawings should only be undertaken after reference and compliance with the

relevant component's technical data. The diagram is not to scale. For more tailored solutions to suit individual applications, please contact Brickworks Building Products. Brickworks Building Products reserves the rights to add, alter or delete components without prior notice.





# INSTALLATION

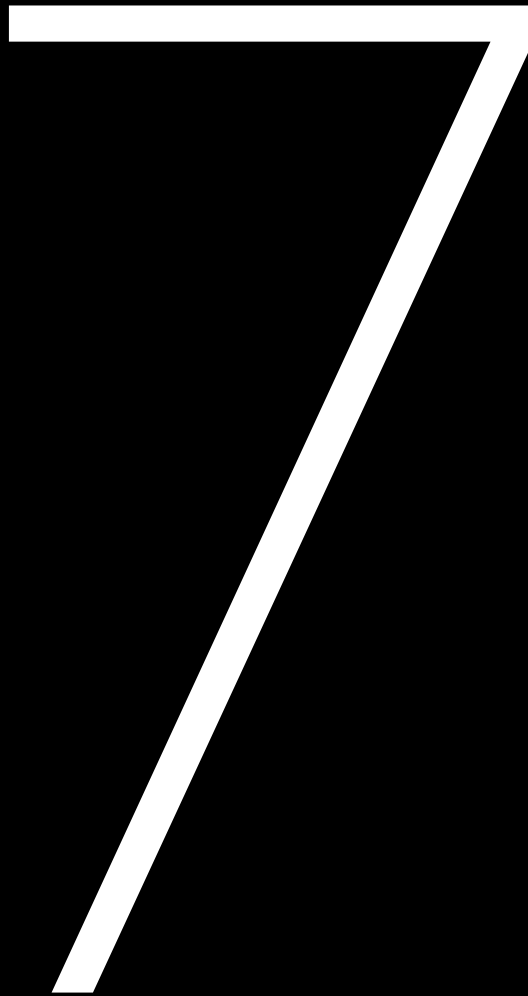

For the most up to date information on Terraçade products and the latest version of this manual, please refer to our website; [www.terraçade.com.au](http://www.terraçade.com.au)

# INSTALLATION

## Components

THE TERRAÇADE TN SYSTEM IS EASILY INSTALLED AS THE TILES ARE SECURELY ATTACHED BY PURPOSE DESIGNED SUSPENSION RAILS.

The speed of installation of the tiles and the effectiveness of the panel support system is dependent on achieving close control of tolerances in the fixings of the vertical support system. The unique design of the vertical suspension rails ensures that the vertical module distance is maintained within the rail.

### Preparation

- 01.** Ensure that adequate structural members are available to fasten the suspension rails to. Additional noggings or purlins may be necessary to accommodate the required span configuration. Design documentation should accommodate these requirements.
- 02.** Specify adequate waterproofing measures for the backup structural wall. For framed systems a waterproof membrane is supplied as part of the system's tested performance. Alternative membranes can be used where properties are equivalent or exceed those listed in the table on page 29.
- 03.** Determine the set-out of tiles, based upon the design requirements. The tiles could be set from the base, the top or from any important structural features.

- 04.** Determine the quantities of the components required for a particular design. Contact a Brickworks Building Products representative if you require assistance.
- 05.** Obtain the correct fasteners, as per the fastener table, for the design.
- 06.** Ensure that the installers are aware that irregularities of shape in backup wall must be packed out or accommodated for, to ensure that the suspension rails are installed correctly.

### Examination of Substructure

- 07.** Examine back-up wall for compliance with design requirements (check for discrepancies with drawings, cracks and other possible air leakage sources).
- 08.** Ensure that adequate support structure is available to comply with the span configurations specified.
- 09.** The maximum horizontal or vertical deviation of a surface from a plane surface (bow) in any 2 m length;
  - Structural Tolerance - 5 mm
  - Non-Structural Framework Tolerance - 3 mm

### Set Out and Coordination

- 10.** Establish and coordinate set-out lines, following design requirements for the set-out of the tiles. For example, the design may require that the tile module is spaced from an important feature or be designed to reduce cut tiles around a window.
- (See below diagram 01 and 02).*
- 11.** Install any secondary framing necessary to support suspension rails including bimetallic separation, line and level.
- 12.** Confirm support centres for rail as required by the span chart have been achieved.

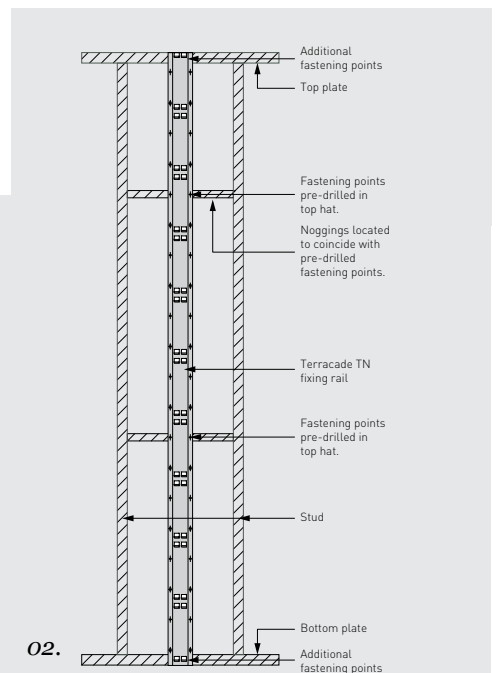
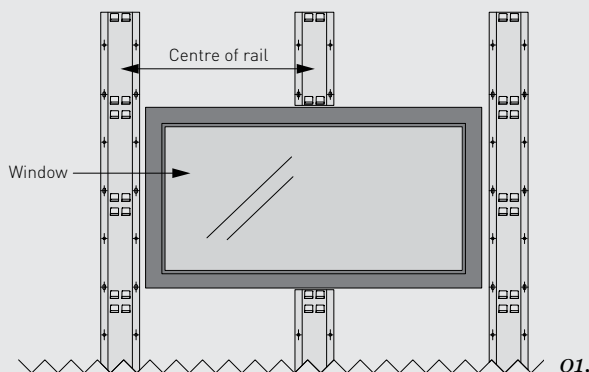

# INSTALLATION

## Components

### Installation of Waterproofing

- 13.** Install Water Resistive Barrier (WRB) membrane system over Rigid Air Barrier (RAB). Check for holes and gaps in the seal and ensure compliance with the manufacturers requirements.

The WRB membrane system must be installed in accordance with the manufacturers instructions and recommendations.

For structures where a Rigid Air Barrier (RAB) is specified by the façade engineer a 6 mm fibre cement board should be used.

### Installation of Suspension Rails, Flashings and Trims

- 14.** Cut suspension rails to size, if necessary, paying particular attention to top and bottom termination and fixing points.
- 15.** Install vertical suspension rails, ensuring that the rails are installed straight and as per the design specifications (with particular reference to the fastener table and the allowable pressures). A level line, spirit level or laser level can be used
- to ensure accuracy. Note that vertical misalignment between adjacent rails must not exceed 1 mm.
- 16.** A set-out tool should be used to ensure continuity of the vertical module when more than one suspension rail is required in one vertical line.
- a.** When attaching a suspension rail above a pre-attached suspension rail, loosely attach the top suspension rail using the slot holes punched in the suspension rail.
- b.** Engage the set-out tool onto the two rails by slotting it over the hangers. (See overleaf diagram 05).
- c.** Once the top suspension rail is positioned correctly and is vertically plumb and level tighten the fastenings and lock the suspension rail into place.
- d.** Remove the set-out tool for use elsewhere.
- 17.** Place fitment sponge vertically onto the suspension rail at the position shown in diagrams 03, 06, 07. Four sponges are required per 588 mm tile and 6 sponges required per 1188 mm tile. (See overleaf diagram 06).
- 18.** Do not leave the fitment sponge exposed to sunlight for more than 24 hours.
- 19.** Install any flashings that may be necessary to maintain the building air seal and weather tightness at openings or adjacent claddings.
- 20.** Check all flashings (corners, at each 2-storey location, around all openings etc) are continuous and complete.
- 21.** If an interstorey seismic flashing is required the up stand must be fixed and taped to the rigid air barrier and must extend over the surrounding profile below. (See overleaf diagram 09).
- 22.** Surrounds shall be fixed to the suspension rail with aluminium flat bar at a maximum 600 mm vertical centres. Flat bars to be fixed with a minimum of three 4 mm x 12.5 mm rivets to the TN.01 suspension rail and three 4 mm x 12.5 mm rivets the TN.09 surround trim. Corner surrounds shall be fixed with gussets to the suspension rail and surround (See below diagram 04).



03.



04.



# INSTALLATION

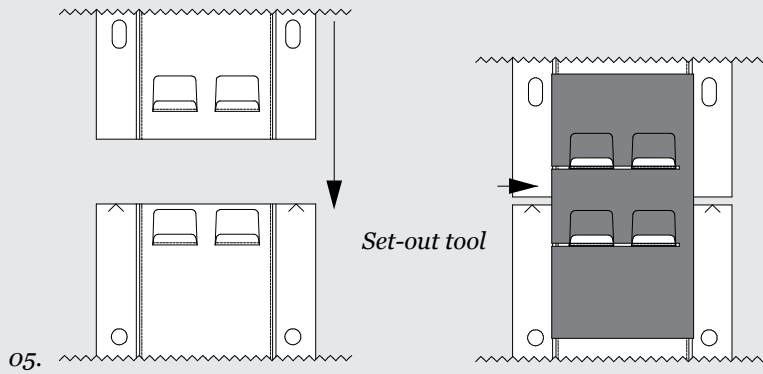

05.

Set-out tool

*TN.E2 Fitment Sponge Set Out for 588 mm Tile*

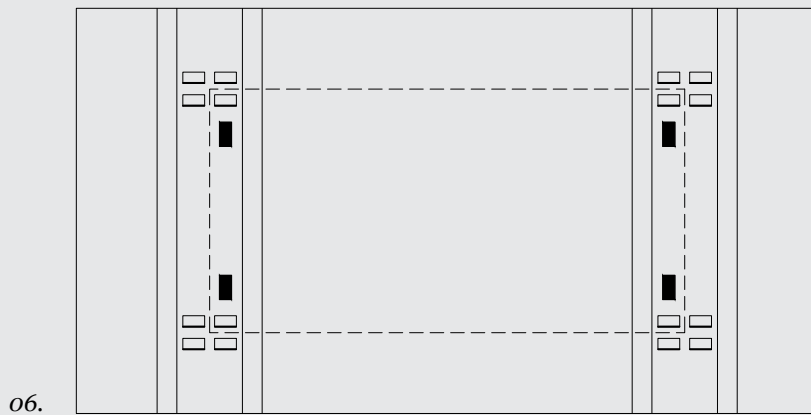

06.

*TN.E2 Fitment Sponge Set Out for 1188 mm Tile*

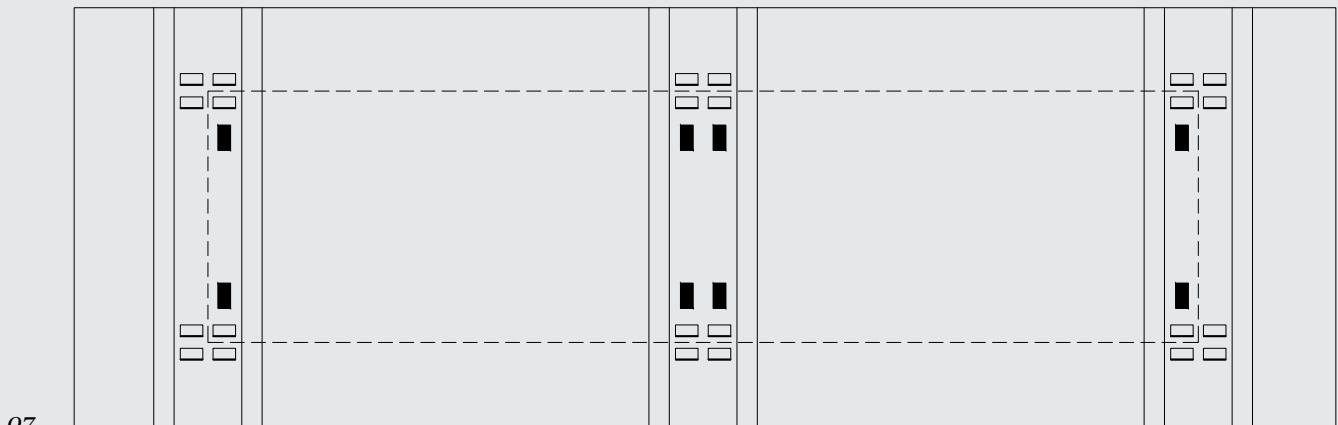

07.

# INSTALLATION

## Installation of Tiles

**23.** Commence installation of tiles starting from the base and working upwards, ensuring horizontal set out lines are maintained.

a. Install tiles onto the vertical suspension rail by initially placing the top receiver of the tile securely on the top hanger. Lift the base of the tile and tilt inwards slightly to engage the bottom hanger. Check that the tile has been securely engaged visually and by physically moving the tile.

(See below diagram 08).

b. Tiles can be cut to any length or height using a wet saw with appropriate continuous rim diamond blades. Surround trims are used to capture cut tiles.

(See details SDO6 to SD10 on pages 47-51).

c. Insert either santoprene or aluminium tile spacers if necessary. Tile spacers will be necessary if a cut tile is not supported by the top hanger to maintain continuity in the tile overlap.

**24.** Insert vertical aluminium jointing strips and fix them mechanically using blind rivets or screws at maximum 600 mm centres. 3M VHB tape may be used to position the joining strip prior to mechanical fixing.

**25.** Brush down or sponge with a moist cloth on completion to remove loose material.

### Notes:

- a. Every length of suspension rail should be fastened at least at one position in the 2 round holes. That is, do not use only the slots to fasten the suspension rail.
- b. Engage the set-out tool onto the two rails by slotting it over the hangers.
- c. If a secondary framing system is required, its suitability should be confirmed by a structural engineer.
- d. It is difficult to remove individual tiles from a wall as it requires 'shuffling' of immediately adjacent tiles. The use of trims and a top wedge should prevent this shuffling as the top tile becomes locked into position.

e. If additional drill holes in the suspension rail are required, they must not be drilled adjacent to the punched hangers. The only exception occurs when drill holes are required at the top and bottom of the suspension rail, for example at the top plate, or bottom plate of a timber frame.

f. Where multiple lengths of the support rails are butted end to end it is recommended that the set-out tool supplied is used to ensure tolerances are maintained.

g. The suspension rails are designed to accommodate the thermal expansion for full lengths when placed using the set-out tool. However, if cut rails are butted against one another a vertical gap of ~5 mm should be left between the rails using the set-out tool to accommodate thermal expansion.

h. If installing tiles on a rake, the tile weight must be supported at least at two locations.

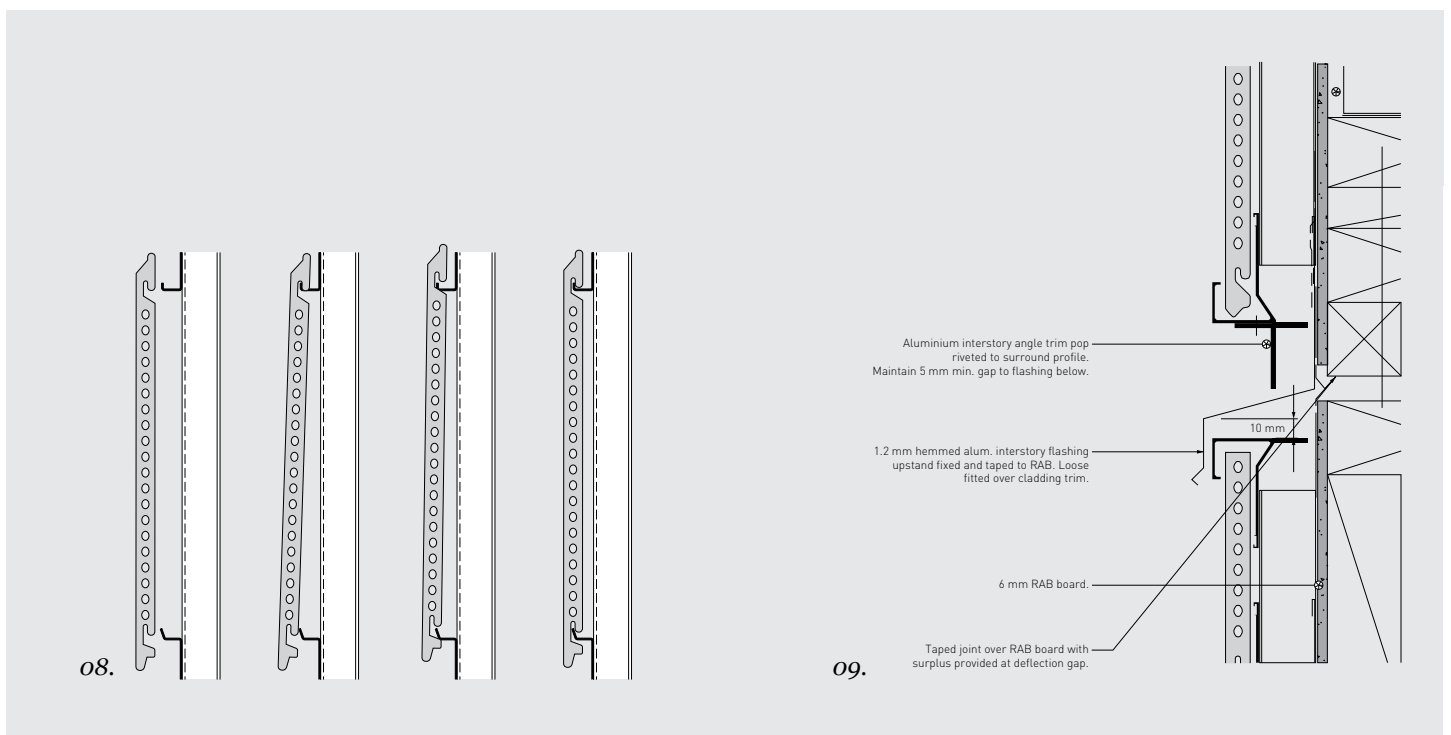

# DISASSEMBLY PROCESS

This procedure explains the standard disassembly of the Terraçade TN system to facilitate the reuse of the tiles, flashings, or complete system for another project. The tiles can be easily removed and replaced with another colour or profile. Any unwanted surrounds, joining strips or rails can be recycled.

## Disassembly process

- 01.** Remove the vertical aluminium jointing strips by removing the blind rivets or screws.
- 02.** Commence disassembly of Terraçade TN starting from the top and working downwards.
- 03.** Where the edge row of tiles is captured in a surround or edge trim, commence removal at the second row of tiles.
- 04.** Tile removal method:
  - a) Lift the base of the tile directly upwards and pull outwards at an angle to simultaneously disengage the tile from both suspension rails.
  - (See below diagram 10).
  - b) For tiles captured by a surround profile or external corner, first remove adjacent row of tiles y sliding slightly to the side of the trim to facilitate disengagement.
- 05.** Remove fitment sponge from rails and surrounds. The fitment sponge cannot be reused.
- 06.** Remove suspension rails, unscrew all fixings.
- 07.** Remove flashings to openings and corner flashings.
- 08.** Remove breathable membrane.
- 09.** Remove any sub-framing if present.

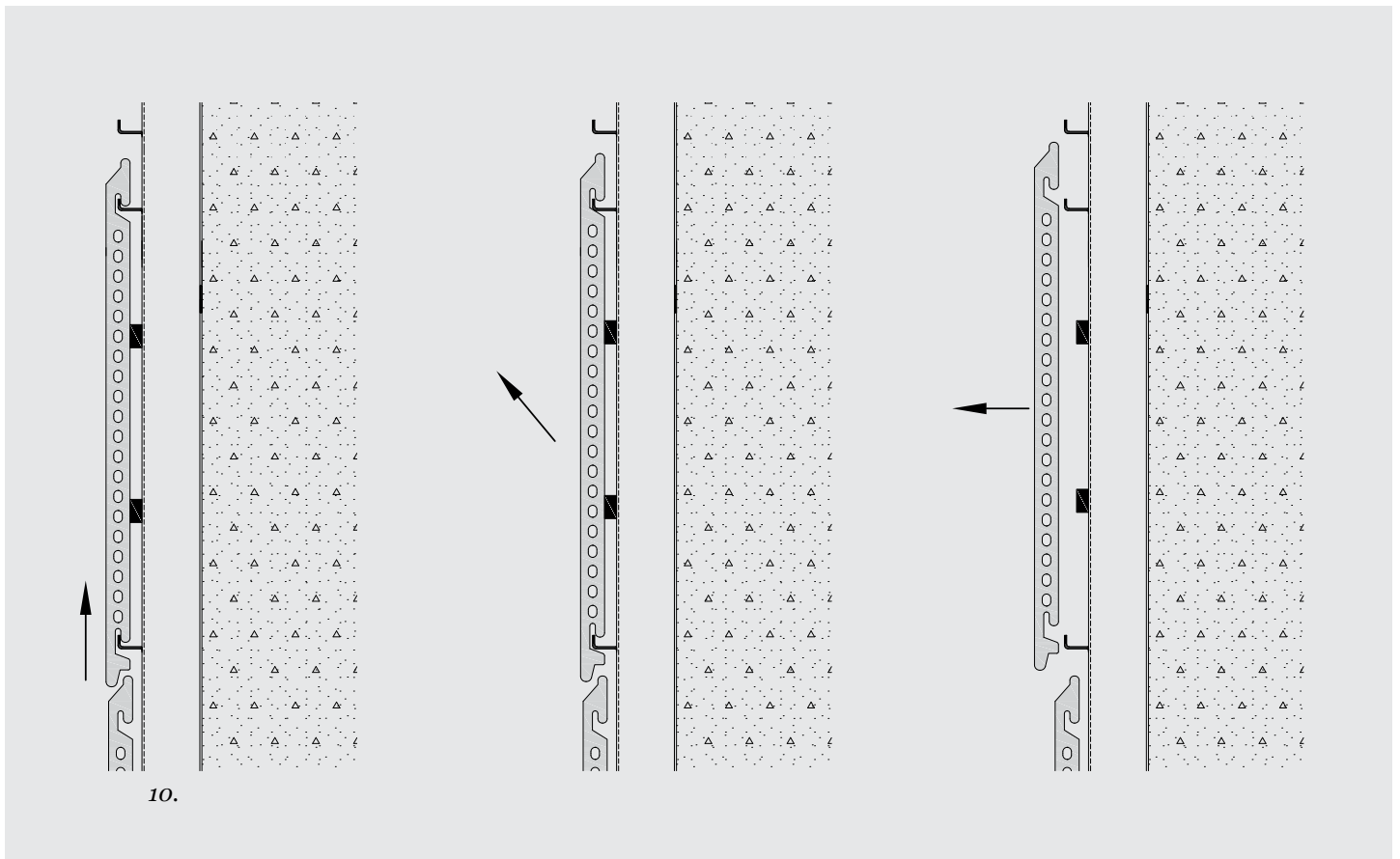

# MAINTENANCE GUIDE

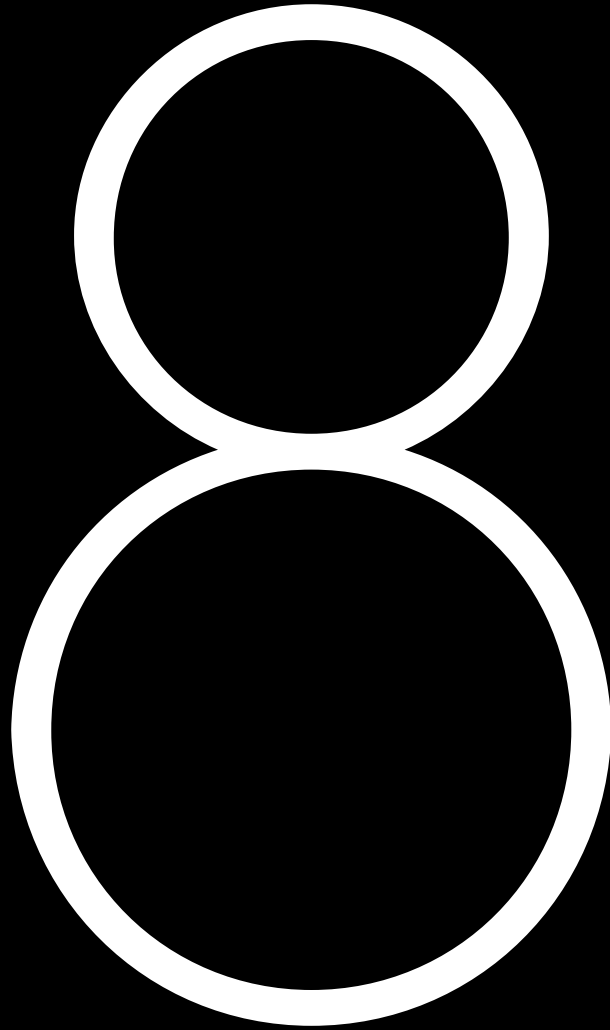

For the most up to date information on Terraçade products and the latest version of this manual, please refer to our website; [www.terraçade.com.au](http://www.terraçade.com.au)

# MAINTENANCE GUIDE

## *For Terraçade Façade System Components*

### **1. System Inspection**

It is recommended that the Terraçade façade system to be inspected at 2 yearly intervals to ensure the integrity of the system. The inspection interval will vary according to the sub-frame and trim components utilised in the system. Below is a summary of cleaning and maintenance information that can be accessed at the Terraçade website.

### **2. Cleaning**

Terraçade tiles are a natural terracotta product and are therefore virtually maintenance free. If you wish to remove any dirt or pollution grime that has built up over time, simply lightly hose or sponge down the tiles with water.

The tiles should be washed down during installation using a sponge with water and a neutral pH cleaner and then rinsed off with clean water. For ongoing maintenance the tiles may be hosed or sponged to remove dust and the build-up of dirt. Normally, cleaning the tiles will be as easy as letting the rain do the work for you.

In addition to the above it is recommended washing of tiles and componentry is combined with the window and general building wash at three monthly intervals.

#### **a. Abseil Methodology**

The Terraçade façade tiles are 14 mm thick and any physical contact by the abseil team needs to be kept to an absolute minimum. The abseil methodology should limit physical contact only to the window/door joinery trims and the inter-storey flashings (if applicable). Should any damage to the tiles or componentry occur during maintenance inform the Building Property Manager. A scope for the remedial work can then be provided by the Terraçade Agent and subsequent work actioned.

### **3. Aluminium Trims**

#### **a. Care & Maintenance Instructions:**

A simple regular clean will minimise the effects of weathering and will remove dirt, grime and other build-up detrimental to all powder coatings.

#### **b. Recommended cleaning method:**

A gentle clean with a soft brush and mild detergent, followed by a fresh water rinse, will maintain the long-term performance of your powder coated products. In rural or normal urban environments cleaning should occur every 12 months. In areas of high pollution, such as industrial areas, geothermal areas or coastal environments, cleaning should occur every three months. In particularly hazardous locations, such as beachfronts, severe marine environments or areas of high industrial pollution, cleaning should be increased to monthly.

#### **c. Recommended cleaning products:**

To protect the surface of your powder coated products, do not use strong solvents, abrasive cleaning products or those products that are recommended for thinning various types of paints. If you need to remove splashed paint, sealants or mastics from your powder coated products, you can use white spirits. When using white spirits, cleaning should be carried out in shade and during cooler temperatures using a soft cloth and gentle wiping only. It is also recommended that, prior to use, a small non-visible area of your powder coated products be tested to ensure that no visual colour change or damage will occur, particularly with bright and deep colours.

### **4. Sealing Tiles**

Terraçade tiles have a hard wearing surface that is resistant to most normal staining agents. In particularly difficult environments, for instance high traffic city areas, Terraçade may be exposed to graffiti vandalism or build up of carbon dirt from passing motor vehicle traffic. A high quality impregnating (penetrating), breathable sealer can be used to make the surface easier to clean and prevent permanent staining as much as possible.

### **5. Replacing Individual Tiles**

It is difficult to remove individual tiles from a wall as it requires 'shuffling' of immediately adjacent tiles. It may be more practical to break the damaged tile with a rubber mallet so that it can be removed piece by piece. Care must be taken if this option is used as falling or sharp pieces of tiles may cause injuries.

To place a new tile into position, insert the top edge of the tile beneath the bottom edge of the tile above. Shuffle the tile above up slightly, ensuring that it is restrained from falling by an assistant. Capture the tile on the top hook first and then the bottom hook. Check that the tile and the tiles above are fully engaged by visual and manual checks.







## QUALITY GUARANTEE

Brickworks Building Products continued commitment to quality and innovation ensures that Terraçade TN will remain the benchmark for excellence for many years to come. Our tradition, experience and financial strength have made Brickworks Building Products the first choice for many architects, builders and designers.

Terraçade TN has a warranty of 20 years on the system and a 100 year warranty on colourfastness and durability, as per Terraçade Warranty. Contact Brickworks Building Products to have an architectural consultant visit you with samples and technical information, or to discuss your next project.

Please note: Photographs should be considered indicative of colour and texture only. Variations in colour and shade are inherent in all clay fired products. All Terraçade tiles and accessories should be ordered at the same time to avoid the possibility of batch to batch variations. No responsibility will be accepted for colour selection, matching, blending and any other physical or colour related defects once the tiles have been incorporated into any construction. Terraçade™ and Terraçade TN™ are registered trademarks of the Brickworks Building Products or its wholly owned subsidiaries. ACN 119 059 513

Australian and New Zealand Patent & Australian and New Zealand Design Registrations.

© 2022 All rights reserved Brickworks Building Products. Whole or partial reproduction of this publication without Brickworks Building Products authorisation infringes reserved right; any utilisation must be previously requested.

# terraçade™

New Zealand

0800 826 827



proud supporters



# BRICKWORKS

— BUILDING PRODUCTS —