

Southern Coloured Masonry Blocks

Victoria



What's inside

- 1 – The Benefits p⁰³
- 2 – Our Range p⁰⁵
 - Southern Veneer p⁰⁶
 - Southern Split Face p⁰⁸
 - Southern Smooth p¹⁰
- 3 – Technical Guide p¹²
- 4 – Get in Touch p²⁷

Southern

—



Products
that last
a lifetime

A BRAND OF

BRICKWORKS



The Benefits

When considering building products to use on your project it's important to understand all the pro's and con's. You know you're making the right choice when you consider the host of benefits the Southern range offers.

Here's what makes the Southern range so unique:



More affordable

For a premium product, our coloured concrete masonry range offers an affordable option.



Extensive colour range

Concrete masonry products are available in a vast range of colour and finish combinations.



Low maintenance

Minimal maintenance, maximum impact. You're guaranteed a long-lasting, tough, and easy to care for solution.



All-weather resistant

Heavy storms. Blistering heat. Sub-zero frosts. While they are not waterproof, our products are designed to hold up to virtually anything our weather systems are capable of throwing at it.



Fire-resistant

All of our products are non-combustible and highly fire resistant – making them ideal for bushfire prone areas.



Termite resistant

With no organic wood materials present in our concrete formulations, our masonry range is naturally termite resistant.



Speed of construction

Concrete masonry products are much faster to build with than some commonly used walling materials and have the added benefit of being both structural and aesthetic.



Our Range

- Southern Veneer
- Southern Split Face
- Southern Smooth



Southern Veneer

The Southern Veneer Range brings together a collection of contemporary colours in one distinctive block size.

Perfect for architectural feature walls, the Southern Veneer range creates a unique finish for creative spaces.

Colours



Riverstone



Desert Fawn



Titanium

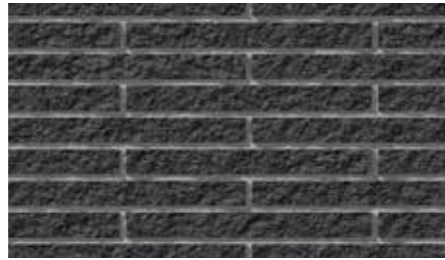

Bluestone

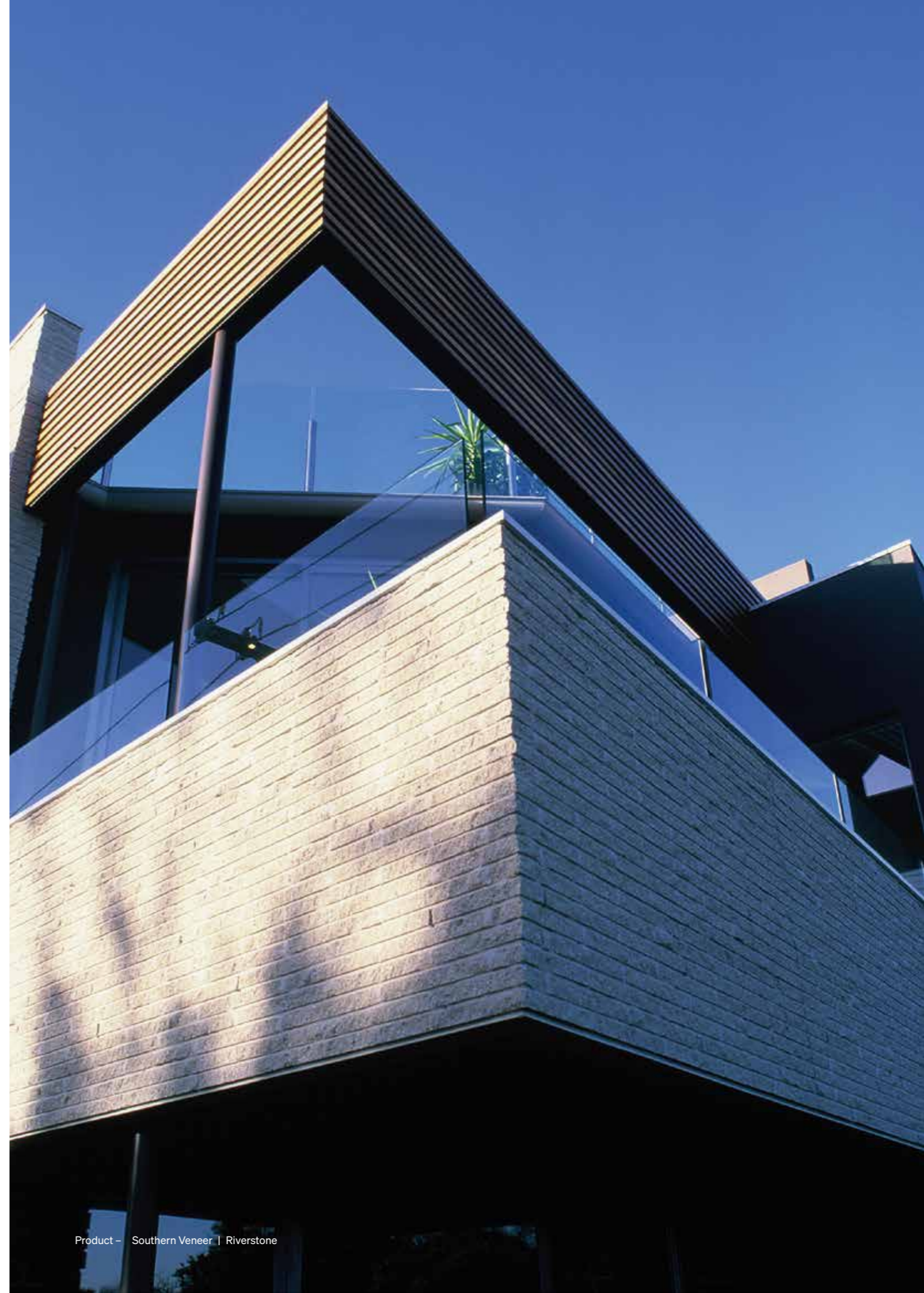

Southern Split Face

The rustic finish of split face creates a distinctive look. The splitting process used to create these blocks produces a bold textured finish.

Colours



Riverstone



Desert Fawn



Titanium

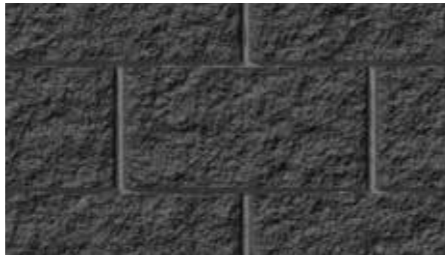

Bluestone

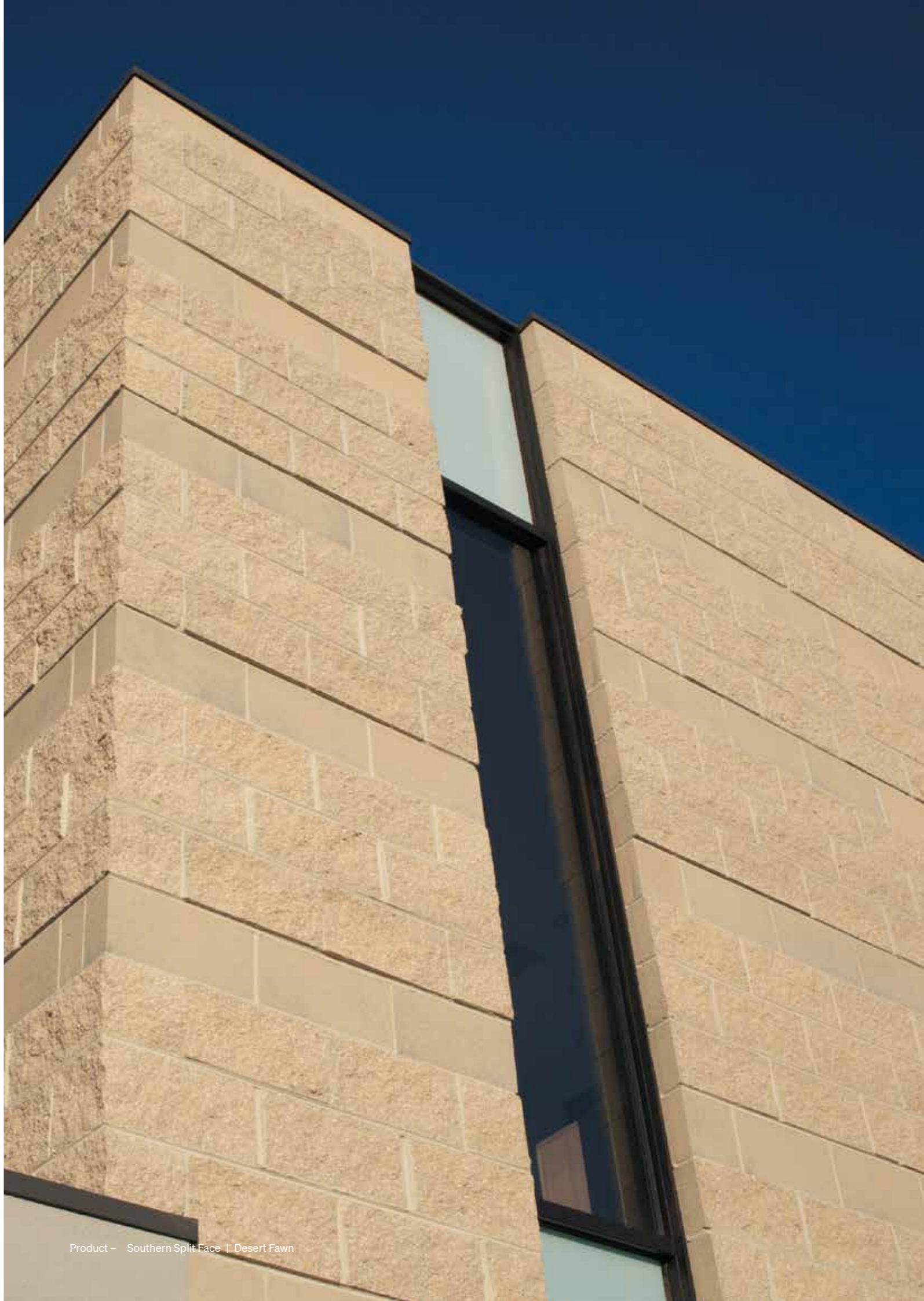

Product – Southern Split Face | Desert Fawn

*Split Face products colour may vary compared to other products in this collection. These products are produced in a different facility and use different materials in their manufacture. Austral Masonry recommends referring to product samples prior to making final selections.

Southern Smooth

Its smooth surface gives a soft glow to any project. Offering contemporary colours from Riverstone to Titanium, there's an option to suit most colour schemes.

Colours

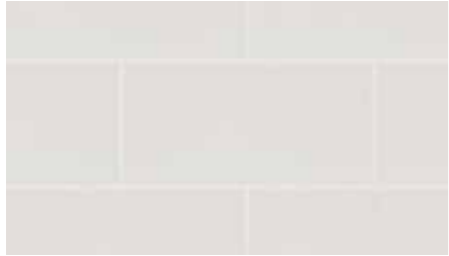

Riverstone



Desert Fawn



Titanium



Bluestone

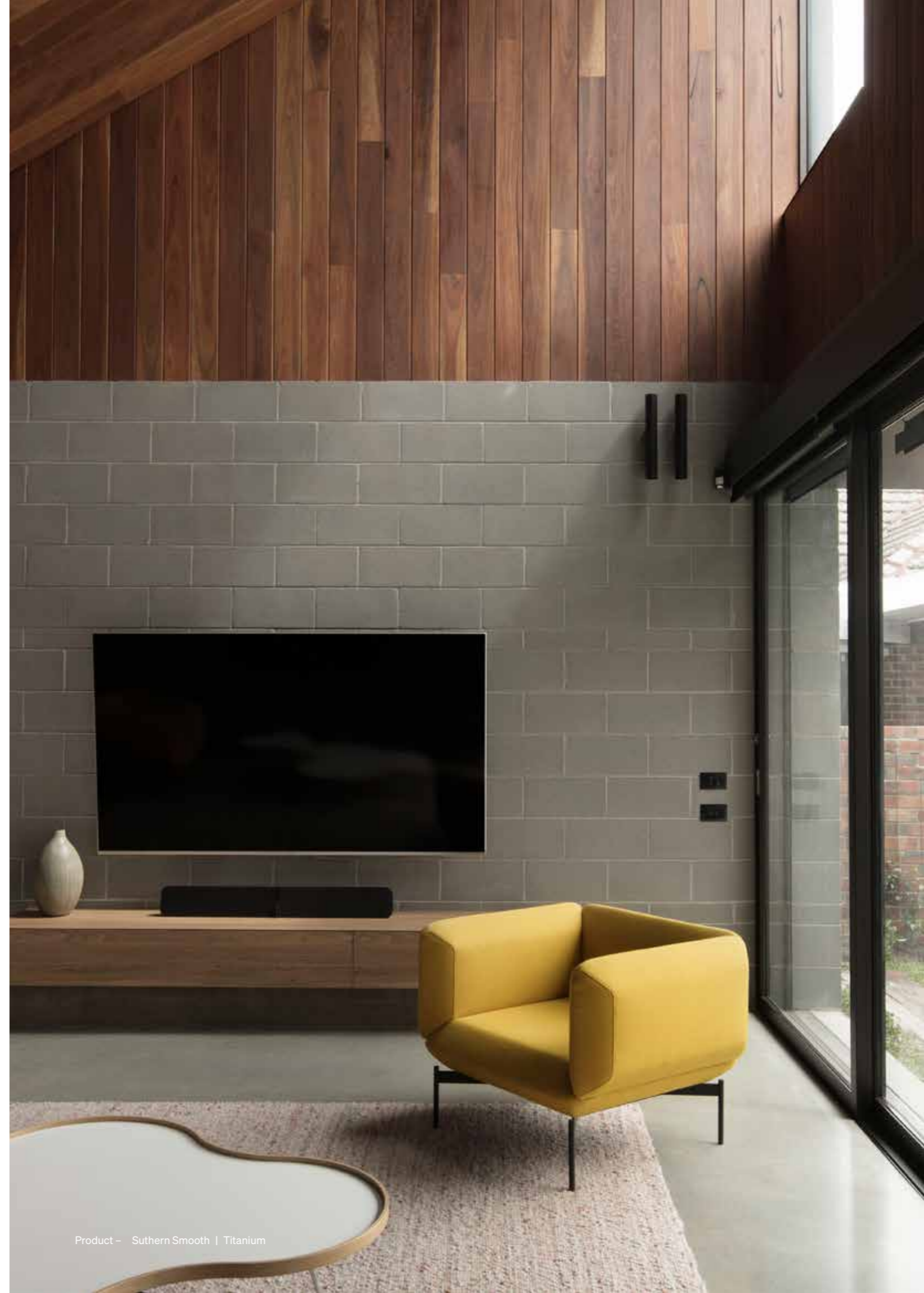



Technical Guide

- Range of Sizes
- Core Filling and Corner Bonding

2

Range of Sizes

The Southern collection is available in a range of sizes to suit various applications.

Material qualities for mortar

One cubic metre of mortar will lay approximately 800 to 1200 200 series blocks.

Mortar mix

Mortar mix options in AS3700 include cement; lime and sand in 1:1:6 proportions for M3 (General Purpose) and in 1:0.5:4.5 proportions for M4 (Exposure Grade). While these make better mortar, the adjacent mixes, without lime, are more common. The following mixes are based on one 20kg bag per mix.

M3 Mortar Mix

General purpose
 -
 One 20kg bag of Off-White cement and oxide with 100kg clean sand. (18 shovels at 5.6kg) 0.1kg of Dynex or similar methyl cellulose plasticiser. This yields 0.08 cubic metres and will lay 60 to 100 blocks.

M4 Mortar Mix

Exposure grade
 -
 One 20kg of Off-White cement and oxide with 80kg clean sand. (14 shovels at 5.7kg) 0.1kg of Dynex or similar methyl cellulose plasticiser. This yields 0.06 cubic metres and will lay 50 to 75 blocks.

Smooth

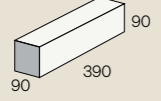
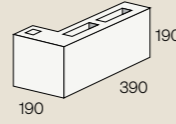
V10-01 Full	V10-83 Solid Half Height	V10-03 Half Cored	V10-25 Corner Return	V10-38 Sill Block	V10-02 Three Quarter
					
Weight: 11kg No. per Pallet: 144 Durability Class: GP	Weight: 6kg No. per Pallet: 288 Durability Class: GP	Weight: 5kg No. per Pallet: 288 Durability Class: GP	Weight: 18kg No. per Pallet: 96 Durability Class: GP	Weight: 6kg No. per Pallet: 288 Durability Class: GP	Weight: 7kg No. per Pallet: 192 Durability Class: GP

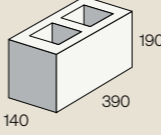
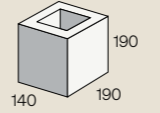
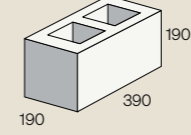
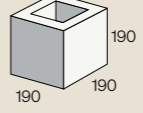
V15-01 Full	V15-03 Full	V20-01 Full	V20-03 Full
			
Weight: 13kg No. per Pallet: 120 Durability Class: GP	Weight: 6kg No. per Pallet: 192 Durability Class: GP	Weight: 16kg No. per Pallet: 90 Durability Class: GP	Weight: 8kg No. per Pallet: 180 Durability Class: GP

Split Face

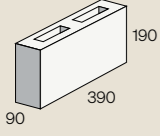
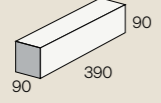
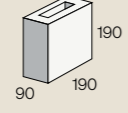
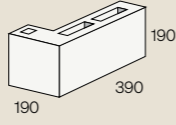
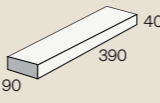
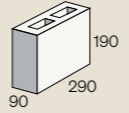
V10-101 Full	V10-109 Solid Half Height	V10-103 Half Cored	V10-26 Corner Return	V10-117 Veneer	V10-102 Three Quarter
					
Weight: 13kg No. per Pallet: 120 Durability Class: GP	Weight: 7kg No. per Pallet: 240 Durability Class: GP	Weight: 7kg No. per Pallet: 240 Durability Class: GP	Weight: 17kg No. per Pallet: 80 Durability Class: GP	Weight: 3kg No. per Pallet: 432 Durability Class: GP	Weight: 10kg No. per Pallet: 120 Durability Class: GP

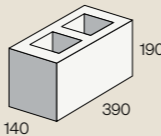
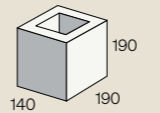
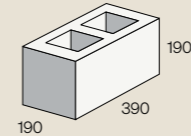
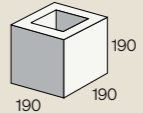
V15-121 Full Cored	V15-123 Half Cored	V20-121 Hollow	V20-123 Half Hollow
			
Weight: 13kg No. per Pallet: 120 Durability Class: GP	Weight: 6kg No. per Pallet: 192 Durability Class: GP	Weight: 18kg No. per Pallet: 90 Durability Class: GP	Weight: 9kg No. per Pallet: 180 Durability Class: GP

Core Filling and Corner Bonding



Core filling

When core filling walls some seepage may occur due to high hydrostatic pressure. Ensure it is cleaned off before it dries, otherwise staining will occur. It is essential that the block work is kept clean from mortar smears. This will eliminate the need for aggressive acid based cleaning solutions which can damage the face or change the colour of the concrete blocks. Storey height walls should be filled in 2 lifts to reduce hydrostatic pressure.

Joints should be finished with an ironing rod to make them smooth, dense and more water resistant. (Mandatory in severe marine environments). Raked joints are NOT permitted in hollow blocks (unless corefilled as per AS3700).

100 Series Corner

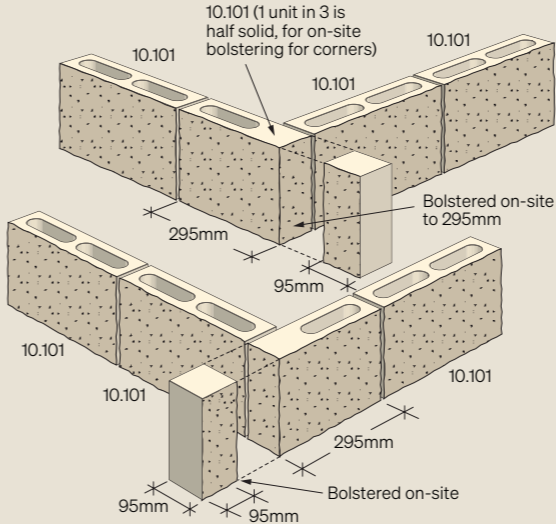

150 Series Corner

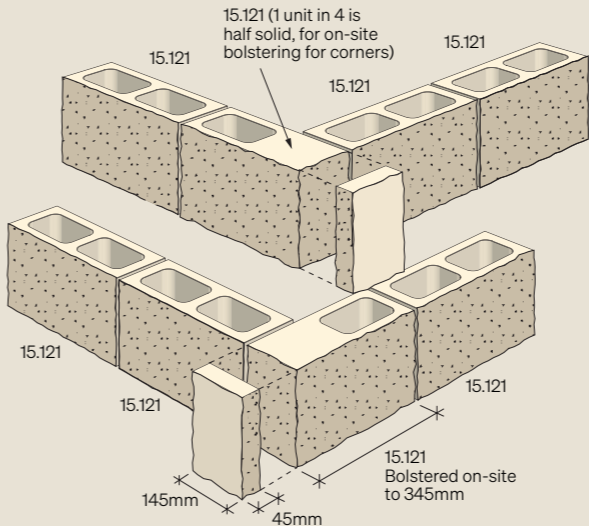

200 Series Corner

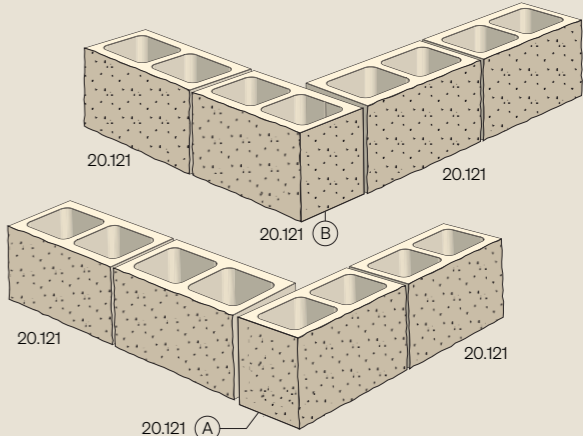

Helpful tips

Block information and some helpful tips before you get started.

1.

Block thickness

Blocks are available in a series of thicknesses:

- **100mm Series**
90mm total block thickness
- **150mm Series**
140mm total block thickness
- **200mm Series**
190mm total block thickness

2.

Block types

Blocks are manufactured to three levels of coring:

- **Solid**
A solid block with no core hole
- **Cored**
< 30% core hole volume
- **Hollow**
>30% core hole volume

3.

Modular planning

The dimensions of masonry units are based on a 100mm module.

The actual size of units shown in this catalogue are generally 10mm smaller than their nominal size to allow for joint thickness. For example, a block having an actual length of 390mm will be classified as having a nominal length of 400mm.

4.

Block laying

Dry units are essential. Blocks should never be wetted prior to the application of mortar.

Blocks should be kept dry when stored on site before use. Whenever work is stopped, the tops of walls should be covered to prevent moisture entering the cores of the blocks.

Blocks should be laid with the thickest shell uppermost. Care shall be taken not to allow mortar to drop into cores if it is to be grouted. A clean out course is recommended and usually specified.

5.

Jointing

The mortar squeezed from the joints should be struck off flush with the wall as each block is laid. When the mortar has stiffened and is firm to the touch, it should be firmly compacted with a jointing tool. This compaction is important since mortar, when hardening, has a tendency to shrink slightly.

6.

Flashing

In cavity walls, flashing shall be placed at an angle across the cavity to discharge moisture towards weep holes. Turn up ends to prevent moisture draining into cavities. Flashing and capping should be provided to the tops of all parapets.

7.

Control joints

When required, control joints should be located:

- At major changes in wall height,
- At changes in wall thickness, other than for piers and buttresses,
- At control joints in footings, in the roof, and in floors,
- At chases and recesses for pipings, columns, fixtures, etc.
- At one or both sides of wall openings,
- Near wall intersections.
- Other than as above, unreinforced masonry should have control joints at 6m centres. 16m if adequately reinforced.

8.

Bond beams

A bond beam is a continuous beam around the exterior of a building for the purpose of providing lateral stability to the walls, and to minimise the possibility of shrinkage cracking at openings. Bond beam blocks should be filled with concrete or grout as specified and suitable reinforcing steel. Reinforcement should be not less than 12mm deformed bars.

9.

Blending

Your blocklayer is a professional tradesman and is responsible for ensuring even colour distribution. The blending instructions attached to all packs recommend:

- Don't mix blocks of different types or qualities (for example, firsts and seconds).
- Work from at least three open packs of the same block type and quality.
- Select the top block from a top corner of each pack.
- Work progressively from a corner down and across each pack in a diagonal pattern. (Don't remove blocks in horizontal layers.)

10.

Cleaning

Care should be taken during construction of masonry walls to prevent excess mortar being smeared over the faces of the blocks. Finished walls should be cleaned down after the mortar has hardened by rubbing with a piece of block or carborundum stone, wire brushing where necessary. Acid must not be used for cleaning concrete masonry walls.

11.

Delivery

Delivering your blocks is the first step in the construction process. Here are a few simple guidelines to help with a smooth delivery:

- Deliver ahead of time, preferably at least a day before work commences. Please give us at least 48 hours notice for subsequent deliveries.
- Take as many blocks as you can in one delivery to ensure priority service and efficient on-site blending.
- Help us find you by giving us a clear street address, including the nearest crossroad. Tell us of any obstacles such as narrow, dead-end or one-way streets etc. Place job site signs prominently.

- Blocks are heavy and a tractor with a full pack weighs about five tonnes. Ensure the ground (including underlying pipes) and any pavement traversed can sustain this weight. Our tractors need at least 2.5 m clear width and 2.6 m height clearance.
- Inspect the delivery and call Austral Masonry™ immediately if there are any problems. Product liability transfers to the purchaser once the units are installed.

Mortex Preblended Mortar

Mortex is a factory manufactured, quality assured premixed M4 rated mortar solution. Its consistency can save labour time, increase efficiency, remove the need for on site blending, and it is compliant with AS3700:2018. Mortex takes the guess work out of mortar blending and reduces the potential for under strength, non compliant mortar use.

This can ultimately reduce potential liabilities, saving money and time on rectifications. With the adoption of ISO9001:2008 principles, the mortar constituents are accurately measured and blended in a controlled environment to ensure consistent, homogeneous mortar is produced on-site.

Colours

White mortar is currently the most popular colour. This is made by mixing light coloured cement and white sand and results in a traditional brick and mortar look. Mortar can be coloured by adding powdered or liquid pigments to the mortar as it is being mixed by the block layer. It can also be tinted to match the brick colour, giving a very even wall colour.

Please confirm with your block layer what their mortar colouring offering is before making your final decision.



MORTEX White

MORTEX Grey

MORTEX Charcoal

Please refer to the MORTEX Charcoal Technical Data Sheet for installation and cleaning guidelines before use.

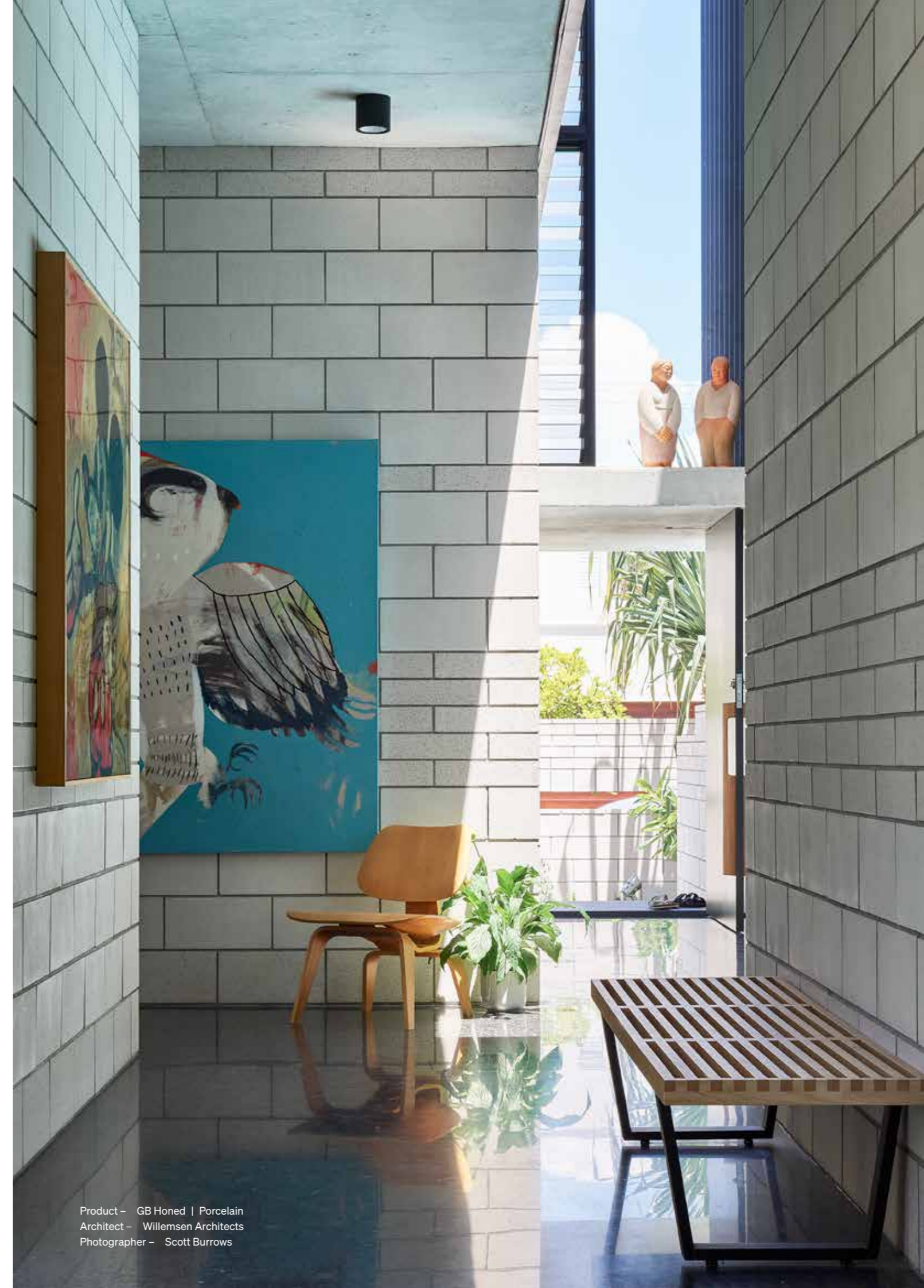

Ideas for Inspiration

Whatever your ideas, we have the products to turn them into reality.



Coloured Masonry Blocks and Breeze Blocks

Our extensive range of architectural masonry products are available in a range of sizes, formats, and finishes from Austral Masonry and GB Masonry.



Grey Masonry Blocks

Austral Masonry offer an extensive range of sizes and formats with light weight options available in selected locations.



Retaining Walls

Choose from concrete retaining wall blocks or concrete sleepers suitable for DIY, general landscaping or large scale commercial retaining wall applications.



Engineered Pavers

Offered exclusively from UrbanStone, the engineered range of pavers are the pinnacle in quality and style.



Natural Stone

Granite, Marble and Limestone flooring, and natural stone wall cladding are style solutions created by nature and perfected by UrbanStone.



Porcelain Stoneware*

Created in Italy by Keope Ceramiche, our porcelain stoneware collection is the epitome of style, designed to suit indoor and outdoor applications.



Concrete Pavers

For commercial and residential applications, our range includes a collection of sizes, textures and a plethora of colours.



Limestone Blocks*

The engineered limestone and natural limestone block range is sourced through quarries in Western Australia with two finishes available to complement the natural limestone colour.



Preblended Mortar and Accessories

From Mortex preblended mortar, to concrete sealers and mortar additives, Austral Masonry offers a host of installation accessories.

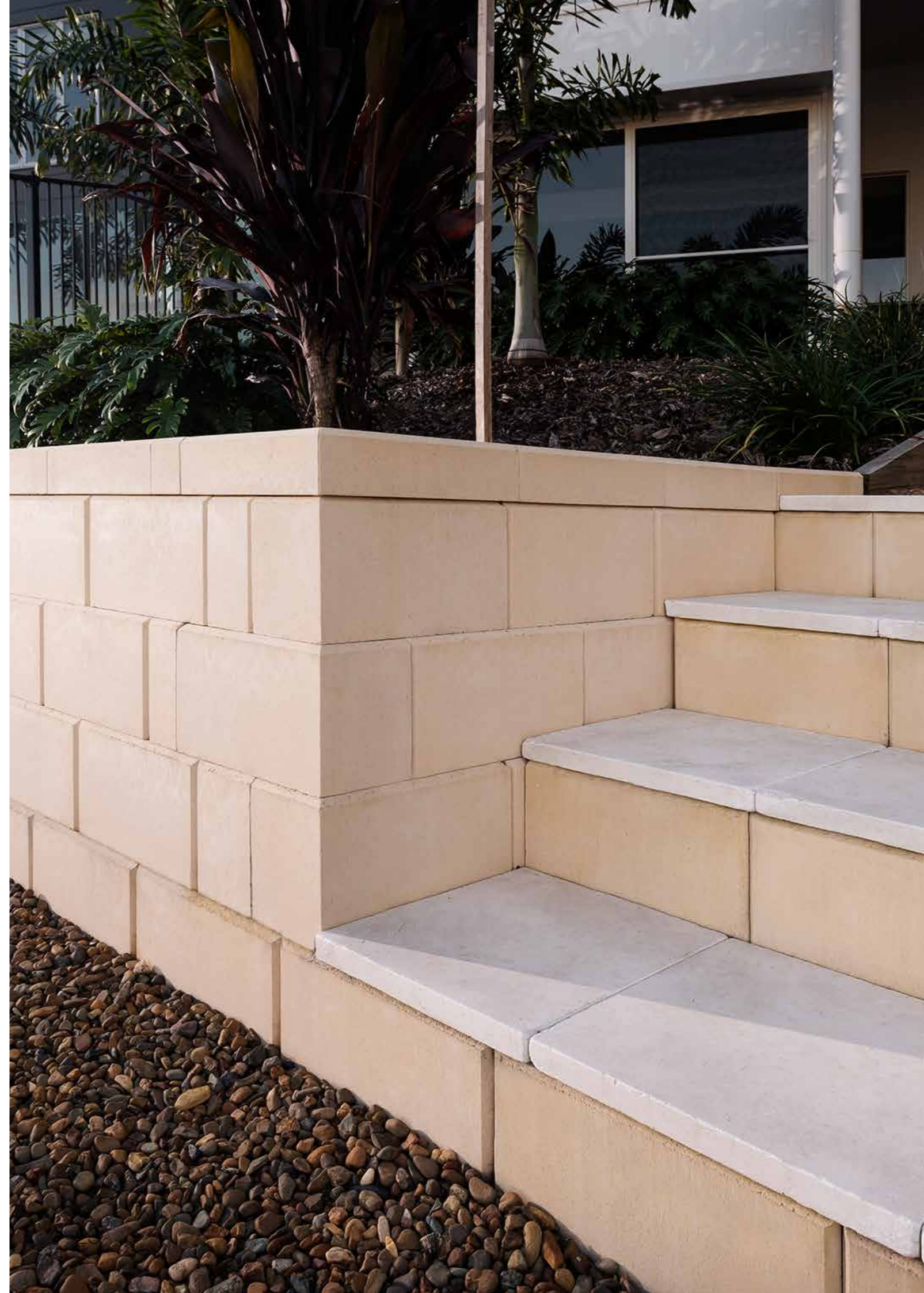

Discover More

Inspiration doesn't always come naturally, and your roof is going to be there for a long time, so it's worth taking your time to enjoy the creative process. From visiting us at our Design Studios, and exploring our iVisualise Tools online, to chatting in person or over the phone, we're here to help.



Discover

Brickworks Design Studios

Your local Brickworks design studio is a one-stop destination for advice and inspiration, where you can experience the quality of our product range first-hand. Our experienced consultants will guide you through the range and help you find the best possible solution for your project – within your budget.

Call.
1300 Masonry

Create

iVisualise Tools

Using artificial intelligence and digital technology, you're now able to experience colours, forms and profiles with our online colour visualisation tool. iVisualise helps make selection seamless and simple – whether you're looking for a traditional product, or something more contemporary.

Visit.
australmasonry.com.au/ivisualise

Learn

Colour Consultations

Building or renovating a home is a major investment – and it should be an enjoyable experience for you. We can help with a one-to-one colour consultation where our experts can guide you on colour trends, the right fit and style, and ideas that will give you a genuinely individual look.

Book.
brickworks.com.au/colour

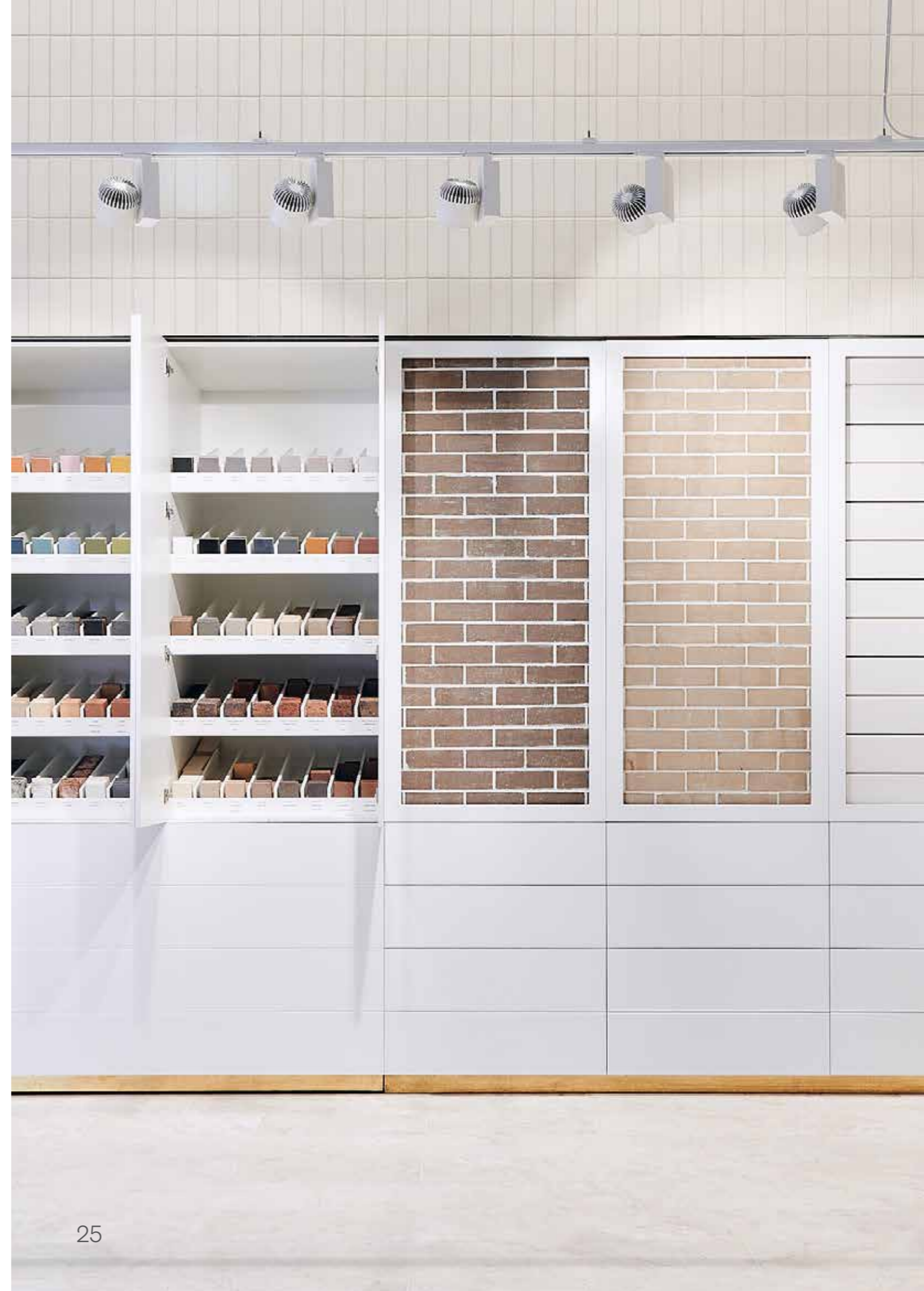

Backed by Brickworks

Local expertise. Global quality. Brickworks Building Products are one of Australia's biggest building material producers. With heritage going all the way back to one of Australia's founding brick producers, we're proud of our reputation for design, innovation and sustainability.

BRICKWORKS

AUSTRALIA

australbricks

australmasonry

australprecast

**southern cross
cement**

bristileroofting

BOWRAL BRICKS

DANIEL ROBERTSON

NUBRIK

GB Masonry

URBANSTONE

Terraçade

CAPITAL BATTENS

NORTH AMERICA

Glen-Gery

Sioux City Brick
Since 1913

**Lawrenceville
BRICK**

**Cushwa
BRICK**

EXCLUSIVE DISTRIBUTOR

La Escandella
ROOFING THE WORLD

S.ANSELMO
vivere la differenza

la paloma
cerámicas

**CERAMICHE
KEOPE**



Get in Touch

For more information, advice and samples get in touch with the Austral Masonry team.

Visit. australmasonry.com.au

Call. 1300 Masonry

Design Centres and Studios

Wollert

Tel. 03 9303 4004
Brickmakers Drive
Wollert VIC 3750

Lynbrook

Tel. 02 4257 1566
40 Northey Rd
Lynbrook VIC 3975

Deer Park

Tel. 03 9303 4713
972 Western Highway
Deer Park VIC 3023

Geelong

Tel. 03 5221 2400
200-204 Torquay Road
Grovedale VIC 3216

Melbourne

Tel. 03 8621 7777
Ground Floor, 367 Collins Street
Melbourne VIC 3000

Follow Us



The product images shown in this brochure give a general indication of product colour for your preliminary selection. Austral Masonry recommends all customers see actual product samples at a selection centre prior to making final selections. 1. Stock colours. Colours other than stock colours are made to order. Contact your nearest Austral Masonry office for your area's stock colours. A surcharge applies to orders less than the set minimum quantity. 2. Colour and texture variation. The supply of raw materials can vary over time. In addition, variation can occur between product types and production batches. 3. We reserve the right to change the details in this publication without notice. 4. For a full set of Terms & Conditions of Sale please contact your nearest Austral Masonry sales office. 5. Important Notice. Please consult with your local council for design regulations prior to the construction of your wall. Councils in general require those walls over 0.5m in height and/or where there is loading such as a car or house near the wall be designed and certified by a suitably qualified engineer. 6. Max wall heights disclaimer. The gravity wall heights are maximum heights calculated in accordance with CMAA MA-53 Appendix D guidelines and a qualified engineer should confirm the suitability of the product for each application. As such, due consideration must be given to but not limited to: Cohesion. Dry backfill, no ingress of any water into the soil behind the retaining wall. All retaining walls are designed for zero surcharge unless noted otherwise. These walls are intended for structure Classification A walls only as defined in AS4678 Earth Retaining Structures as being where failure would result in minimal damage and/or loss of access.

Visit. australmasonry.com.au

Call. 1300 Masonry

A BRAND OF

BRICKWORKS

